



# *GREEN LAKE COUNTY*

*571 County Road A, Green Lake, WI 54941*

---

**Original Post Date: June 5<sup>th</sup>, 2026**

**Amended Post Date:**

**The following documents are included in the packet for the Highway & Highway AdHoc Committee Meeting on June 10<sup>th</sup>, 2026:**

- 1) Amended Agenda
- 2) Minutes: 05-13-2026
- 3) Culvert Bids
- 4) Financial Report
- 5) Commissioner's Report
- 6) Facility Update



# GREEN LAKE COUNTY OFFICE OF THE COUNTY CLERK

Samantha Stobbe  
County Clerk

Office: 920-294-4005  
FAX: 920-294-4009

## Highway & Highway AdHoc Joint Committee Meeting

Date: Wednesday, June 10<sup>th</sup>, 2026 Time: 3:00 PM  
Green Lake County Government Center  
571 County Road A, Green Lake, WI 54941

### \*AMENDED AGENDA

#### Committee Members

Bob Schweder  
Chuck Buss – Vice Chair  
Dennis Mulder - Chair  
Harley Reabe  
Charlie Wielgosh

#### AdHoc Highway Committee Members

Dave Abendroth  
Don Lenz

Samantha Stobbe,  
Secretary

This agenda gives notice of a meeting of the Highway Committee. It is possible that individual members of other governing bodies of Green Lake County government may attend this meeting for informative purposes. Members of the Green Lake County Board of Supervisors or its committees may be present for informative purposes but will not take any formal action. A majority or a negative quorum of the members of the Green Lake County Board of Supervisors and/or any of its committees may be present at this meeting. See State ex rel. Badke v. Vill. Bd. of Vill. of Greendale, 173 Wis.2d 553, 578, 494 N.W. 2d 408 (1993).

1. Call to Order
2. Certification of Open Meeting Law
3. Pledge of Allegiance
4. \*Approval of Minutes: 05/13/2026
5. Culvert Bid Approval
6. Financial report
7. Commissioner's report
8. Facility update
9. Committee Discussion
  - Future Meeting Dates: TBD
  - Future Agenda Items for Action & Discussion
10. Adjourn

#### Microsoft Teams meeting

#### [JOIN MEETING NOW](#)

Meeting ID: 234 446 176 917 0

Passcode: YG2hF7ng

[Need help?](#) | [System reference](#)

#### Dial in by phone

[+1 920-515-0745,,613047929#](#) United States, Appleton

#### [Find a local number](#)

Phone conference ID: 613 047 929#

For organizers: [Meeting options](#) | [Reset dial-in PIN](#)

Please accept at your earliest convenience. Thank you!

[Org help](#) | [Privacy and security](#)

**Please note: Meeting area is accessible to the physically disabled. Anyone planning to attend who needs visual or audio assistance, should contact the County Clerk's Office, 294-4005, not later than 3 days before date of the meeting.**

**HIGHWAY & HIGHWAY ADHOC JOINT COMMITTEE MEETING**  
**May 13, 2026**

The regular meeting of the Highway Committee was called to order by County Clerk Samantha Stobbe at 1:00 PM on Wednesday, May 13, 2026 at the New Green Lake County Highway Building, Princeton, WI. The requirements of the open meeting law were certified as being met. The Pledge of Allegiance was recited.

Present: Dennis Mulder  
Chuck Buss  
Bob Schweder  
Harley Reabe  
Don Lenz  
Dave Abendroth  
Charlie Wielgosh

Absent:

Other County Employees Present: Samantha Stobbe, County Clerk; Derek Mashuda, Highway Commissioner; Mike Van Meel, Maintenance Supervisor; Jeff Mann, Corporation Counsel; County Manager, Jason Jerome; Kayla Yonke, Finance Director; Sophia Walters, HR Coordinator

**ELECTION OF CHAIR**

County Clerk Samantha Stobbe called for nominations for Chair.  
***Motion/second (Buss/Wielgosh)*** nominated Dennis Mulder for Chairman.

***Motion/second (Buss/Schweder)*** to close nominations and cast a unanimous ballot for Dennis Mulder as Chair of the Highway committee. Motion carried with no negative vote.

**ELECTION OF VICE-CHAIR**

Chair Dennis Mulder called for nominations for Vice-Chair.  
***Motion/second (Schweder/Wielgosh)*** nominated Chuck Buss for Vice-Chair.

***Motion/second (Schweder/Wielgosh)*** to close nominations and cast a unanimous ballot for Chuck Buss as Vice-Chair of the Highway committee. Motion carried with no negative vote.

**MINUTES**

***Motion/second (Buss/Schweder)*** to approve the minutes of the 03/11/2026 meeting as read with no errors or corrections. Motion carried with no negative vote.

**ORDINANCE**

- Ordinance Authorizing Highway Committee and Designee to Enter into Contracts with Municipalities within the County

Highway Commissioner Derek Mashuda gave an overview of the ordinance.

***Motion/second (Buss/Reabe)*** to approve the Ordinance and forward on to County Board. Motion carried with no negative vote.

**FINANCIAL REPORT**

Highway Commissioner Derek Mashuda gave a brief overview of the revenues and expenditures.

**COMMISSIONER'S REPORT**

Highway Commissioner Derek Mashuda gave an update on the previous month's activities and upcoming projects within the department.

**FACILITY UPDATE**

Highway Commissioner Derek Mashuda updated the committee on the change orders from the previous meeting. Discussion held.

**FACILITY TOUR**

The committee received a tour of the new facility grounds.

Harley Reabe left the meeting at 1:36PM.

Charlie Wielgosh left the meeting at 1:48PM.

**COMMITTEE DISCUSSION**

**Future meeting date: Regular meeting – June 10, 2026 @ 3:00 PM**

**Future agenda items:**

**ADJOURNMENT**

Chair Mulder adjourned the meeting at 2:18PM.

Submitted by,

Samantha Stobbe  
County Clerk

DRAFT

## 2026 Pipe Bids

Product	Metal Culverts	WI Tubing	Skalitzky		
12" HDPE	\$8.10	\$6.02	\$7.98		
18" HDPE	\$15.05	\$11.10	\$14.90		
24" HDPE	\$24.55	\$19.11	\$24.20		
30" HDPE	\$34.95	\$27.78	\$32.00		
36" HDPE	\$45.90	\$35.34	\$44.00		
42" HDPE					
<b>Pipe Total</b>					
12" AEW	\$85.15	\$91.68	\$105.00		
18" AEW	\$137.05	\$144.70	\$169.00		
24" AEW	\$204.05	\$234.31	\$269.00		
30" AEW	\$466.00	\$471.16	\$520.00		
36" AEW	\$657.00		\$750.00		
42" AEW					
<b>AEW Total</b>					

1/1/2026 Thru 4/30/2026 ( 4 MONTHS EST DPRN ) (ALL WO TYPES) (ALL WO KINDS)

Equipment	Total-cost	Fuel	Lube	Lab+fbn	Part	Overhead	Tire/batt	Sundry	Dprn-mnthly	Units	Revenue
002	1,736.97	1,549.83	4.50	92.84	0.00	89.80	0.00	0.00	0.00	371.00	5,936.00
003	3,276.76	1,258.97	23.91	501.47	18.39	485.02	985.00	4.00	0.00	309.75	4,956.00
004	2,319.31	2,063.64	0.00	71.51	115.00	69.16	0.00	0.00	0.00	6,590.00	4,876.60
005	2,025.37	1,148.16	23.91	412.27	42.28	398.75	0.00	0.00	0.00	0.00	0.00
006	1,525.71	696.55	45.11	388.21	8.36	375.48	0.00	12.00	0.00	205.25	3,284.00
007	1,162.54	867.66	0.00	143.03	0.00	138.34	0.00	13.51	0.00	176.00	4,763.64
008	363.53	363.53	0.00	0.00	0.00	0.00	0.00	0.00	0.00	83.50	1,358.43
009	3,576.54	1,657.03	39.84	42.91	108.59	41.50	0.00	0.00	1,686.67	10,407.00	7,701.18
013	469.40	469.40	0.00	0.00	0.00	0.00	0.00	0.00	0.00	222.00	5,998.50
015	821.36	417.45	105.32	228.83	69.76	0.00	0.00	0.00	0.00	53.50	1,445.68
016	3,024.45	1,187.23	0.00	0.00	0.00	0.00	0.00	0.00	1,837.22	323.00	5,171.90
017	2,622.41	479.38	40.27	1,002.92	129.80	970.04	0.00	0.00	0.00	107.00	2,891.16
018	6,700.38	364.38	8.28	1,373.32	250.79	1,328.30	0.00	74.31	3,301.00	49.00	1,323.99
019	958.47	958.47	0.00	0.00	0.00	0.00	0.00	0.00	0.00	313.50	5,030.63
024	470.74	470.74	0.00	0.00	0.00	0.00	0.00	0.00	0.00	76.00	1,216.00
025	1,573.36	1,270.08	20.92	123.68	31.06	119.62	0.00	8.00	0.00	351.75	5,633.85
026	17,275.87	172.37	85.90	1,200.09	14,379.71	1,160.74	0.00	277.06	0.00	18.25	1,460.70
027	5,541.77	2,599.93	216.03	644.24	1,458.46	623.11	0.00	0.00	0.00	168.00	14,939.83
028	3,309.97	2,400.67	272.89	260.65	123.66	252.10	0.00	0.00	0.00	159.75	14,344.89
030	3,257.21	728.64	81.32	1,037.62	56.48	1,003.60	0.00	349.55	0.00	63.50	7,750.58
031	5,814.88	1,438.45	130.17	1,828.27	186.94	1,768.31	0.00	462.74	0.00	69.50	6,663.49
032	5,778.67	1,167.68	185.35	1,939.22	566.71	1,875.64	0.00	44.07	0.00	95.25	9,008.01
033	1,983.40	0.00	0.00	984.36	26.69	952.08	0.00	20.27	0.00	2.25	198.32
035	7,180.06	1,064.39	26.87	151.17	236.32	146.21	0.00	107.10	5,448.00	56.50	4,273.21
036	9,865.95	2,965.25	377.50	2,797.78	868.68	2,706.02	0.00	150.72	0.00	146.75	13,243.12
037	11,700.49	1,854.27	103.23	633.69	64.71	612.92	0.00	0.00	8,431.67	282.00	15,486.33
040	1,615.85	285.52	0.00	0.00	0.00	0.00	0.00	0.00	1,330.33	26.75	2,802.93
044	7,985.76	562.13	137.93	2,383.46	1,335.60	2,305.32	803.30	458.02	0.00	41.75	3,966.34
045	2,140.73	2,140.73	0.00	0.00	0.00	0.00	0.00	0.00	0.00	288.50	25,481.36
048	2,306.07	1,131.02	0.00	286.04	51.93	276.66	499.62	60.80	0.00	86.00	7,633.01
050	8,586.13	2,491.38	19.35	100.12	60.50	96.84	0.00	42.31	5,775.63	172.75	15,777.25
051	6,504.25	441.40	0.00	2,229.33	1,502.77	2,156.22	0.00	174.53	0.00	21.50	2,106.59
052	451.82	0.00	0.00	162.47	0.00	157.14	0.00	132.21	0.00	1.50	132.21
053	9,280.62	2,103.19	0.00	429.06	15.34	415.00	0.00	132.70	6,185.33	124.75	11,268.77
058	13,777.66	3,011.51	524.58	751.87	2,230.01	727.22	0.00	88.15	6,444.32	150.75	13,485.50
059	14,066.57	2,447.10	200.63	498.93	2,635.08	482.57	1,357.94	0.00	6,444.32	130.00	11,458.22
061	10,708.12	2,767.22	85.17	327.79	87.28	317.05	1,357.94	0.00	5,765.67	190.25	17,324.07
062	11,716.86	1,988.63	51.91	1,865.09	0.00	1,803.92	0.00	235.31	5,772.00	168.00	14,878.07
063	10,869.33	2,603.32	11.32	231.80	0.00	224.20	678.97	247.05	6,872.67	214.00	19,404.15
064	9,605.38	2,512.55	68.23	70.93	12.40	68.60	0.00	0.00	6,872.67	203.00	17,936.56
065	12,268.59	2,879.13	143.29	440.35	333.19	425.91	0.00	242.39	7,804.33	224.75	20,012.26
066	6,359.09	256.09	0.00	0.00	0.00	0.00	0.00	0.00	6,103.00	6.50	678.69
1000	5,946.24	0.00	0.00	2,032.33	0.00	1,965.70	0.00	212.21	1,736.00	41.50	1,322.19
101	400.00	0.00	0.00	0.00	0.00	0.00	0.00	0.00	400.00	0.00	0.00
1027	225.09	0.00	0.00	114.42	0.00	110.67	0.00	0.00	0.00	29.50	250.10
1028	0.00	0.00	0.00	0.00	0.00	0.00	0.00	0.00	0.00	50.75	427.33
103	773.98	0.00	11.85	141.86	9.06	137.21	0.00	0.00	474.00	25.50	0.00
1035	233.67	0.00	0.00	0.00	0.00	0.00	0.00	0.00	233.67	0.00	0.00
1036	0.00	0.00	0.00	0.00	0.00	0.00	0.00	0.00	0.00	69.50	586.90
1048	0.00	0.00	0.00	0.00	0.00	0.00	0.00	0.00	0.00	21.00	176.83
1050	283.85	0.00	0.00	144.29	0.00	139.56	0.00	0.00	0.00	30.25	255.57
1051	0.00	0.00	0.00	0.00	0.00	0.00	0.00	0.00	0.00	3.50	29.47
1053	283.85	0.00	0.00	144.29	0.00	139.56	0.00	0.00	0.00	32.00	275.33
1058	992.81	0.00	0.00	206.13	571.31	199.37	0.00	16.00	0.00	42.50	359.97
1059	0.00	0.00	0.00	0.00	0.00	0.00	0.00	0.00	0.00	24.50	206.29
1061	624.49	0.00	0.00	314.65	5.51	304.33	0.00	0.00	0.00	9.50	80.00
1063	248.00	0.00	0.00	0.00	0.00	0.00	0.00	0.00	248.00	54.00	459.75
1064	248.00	0.00	0.00	0.00	0.00	0.00	0.00	0.00	248.00	10.25	86.38
1065	248.00	0.00	0.00	0.00	0.00	0.00	0.00	0.00	248.00	1.00	8.42
1066	186.00	0.00	0.00	0.00	0.00	0.00	0.00	0.00	186.00	0.00	0.00
114R	651.33	0.00	0.00	0.00	0.00	0.00	0.00	0.00	651.33	0.00	0.00
114S	1,209.33	0.00	0.00	0.00	0.00	0.00	0.00	0.00	1,209.33	0.00	0.00
115	607.59	0.00	2.96	257.44	98.19	249.00	0.00	0.00	0.00	9.00	403.92
130	785.42	0.00	23.71	283.71	203.59	274.41	0.00	0.00	0.00	0.00	0.00
134	1,710.92	237.97	0.00	28.61	0.00	27.67	0.00	0.00	1,416.67	122.00	5,038.87
136	63.20	63.20	0.00	0.00	0.00	0.00	0.00	0.00	0.00	25.75	1,074.77
142	592.00	0.00	0.00	0.00	0.00	0.00	0.00	0.00	592.00	0.00	0.00
143	300.47	0.00	5.93	143.03	9.11	138.34	0.00	4.06	0.00	0.50	4.06
193	15.92	15.92	0.00	0.00	0.00	0.00	0.00	0.00	0.00	3.00	105.72
195	6,250.57	2,425.06	106.57	1,455.47	434.80	1,407.73	0.00	420.94	0.00	272.25	19,591.11
196	0.00	0.00	0.00	0.00	0.00	0.00	0.00	0.00	0.00	237.75	4,545.78
197	5,830.33	58.60	26.85	743.70	436.33	719.31	0.00	196.54	3,649.00	23.50	2,119.22
197C	188.42	0.00	0.00	0.00	0.00	0.00	0.00	0.00	188.42	0.00	0.00
197G	425.00	0.00	0.00	0.00	0.00	0.00	0.00	0.00	425.00	15.75	306.87
206	960.96	178.59	32.21	269.99	192.01	261.14	0.00	27.02	0.00	46.00	1,027.64
208	0.00	0.00	0.00	0.00	0.00	0.00	0.00	0.00	0.00	26.50	659.03
211	224.67	0.00	0.00	0.00	0.00	0.00	0.00	0.00	224.67	26.50	615.53
212	319.00	0.00	0.00	0.00	0.00	0.00	0.00	0.00	319.00	25.25	603.22
221	20,286.74	0.00	64.43	1,607.71	13,546.94	1,554.99	0.00	0.00	3,512.67	0.50	143.87
225	4,451.74	89.71	27.97	1,072.68	17.14	1,037.51	1,749.55	457.18	0.00	68.00	7,310.01

1/1/2026 Thru 4/30/2026 ( 4 MONTHS EST DPRN ) (ALL WO TYPES) (ALL WO KINDS)

<u>Equipment</u>	<u>Total-cost</u>	<u>Fuel</u>	<u>Lube</u>	<u>Lab+fben</u>	<u>Part</u>	<u>Overhead</u>	<u>Tire/batt</u>	<u>Sundry</u>	<u>Dprn-mnthly</u>	<u>Units</u>	<u>Revenue</u>
303	5,686.55	93.08	0.00	343.26	2,259.49	332.00	0.00	120.72	2,538.00	31.00	1,955.65
304	38.71	0.00	38.71	0.00	0.00	0.00	0.00	0.00	0.00	22.00	907.28
305	2,758.89	186.61	0.00	14.30	457.48	13.83	0.00	0.00	2,086.67	60.25	2,508.19
308	246.64	0.00	0.00	57.21	0.00	55.33	121.16	12.94	0.00	0.75	38.81
311	1,088.43	0.00	0.00	0.00	0.00	0.00	0.00	0.00	1,088.43	0.00	0.00
314	3,988.67	0.00	0.00	0.00	0.00	0.00	0.00	0.00	3,988.67	0.75	29.63
323	233.74	0.00	0.00	100.12	10.90	96.84	0.00	25.88	0.00	0.50	25.88
334	0.00	0.00	0.00	0.00	0.00	0.00	0.00	0.00	0.00	3.50	301.81
336	376.53	376.53	0.00	0.00	0.00	0.00	0.00	0.00	0.00	40.25	3,479.19
337	6,767.32	1,113.12	3.90	40.31	0.00	38.99	0.00	0.00	5,571.00	120.00	11,981.82
356	5,277.76	0.00	40.27	772.31	491.83	746.99	0.00	60.36	3,166.00	1.00	60.36
432	0.00	0.00	0.00	0.00	0.00	0.00	0.00	0.00	0.00	10.00	281.40
436	0.00	0.00	0.00	0.00	0.00	0.00	0.00	0.00	0.00	61.00	1,717.95
455	930.66	0.00	0.00	314.65	102.98	304.33	0.00	208.70	0.00	2.50	208.70
456	2,148.26	93.28	163.32	816.10	217.47	789.33	0.00	68.76	0.00	12.00	1,001.76
457	1,173.85	321.30	94.52	206.13	352.53	199.37	0.00	0.00	0.00	42.75	3,777.53
458	378.97	0.00	0.00	0.00	0.00	0.00	0.00	0.00	378.97	58.50	1,646.19
459	378.97	0.00	0.00	0.00	0.00	0.00	0.00	0.00	378.97	42.00	1,181.88
500	870.19	191.78	32.21	269.99	54.93	261.14	0.00	60.14	0.00	75.25	4,999.61
561	3,329.53	0.00	0.00	326.62	0.00	315.91	0.00	0.00	2,687.00	0.00	0.00
570	965.18	273.13	0.00	0.00	15.72	0.00	0.00	0.00	676.33	220.00	4,488.00
571	5,970.19	97.83	563.66	1,618.35	1,448.74	1,565.28	0.00	0.00	676.33	111.00	2,264.40
573	168.83	0.00	0.00	85.82	0.00	83.01	0.00	0.00	0.00	0.00	0.00
574	0.00	0.00	0.00	0.00	0.00	0.00	0.00	0.00	0.00	44.00	421.52
575	8,071.47	407.66	16.11	1,037.69	115.30	1,003.65	0.00	628.06	4,863.00	61.50	4,022.10
577	279.07	0.00	0.00	141.86	0.00	137.21	0.00	0.00	0.00	0.00	0.00
578	371.67	0.00	0.00	0.00	0.00	0.00	0.00	0.00	371.67	0.00	0.00
581	435.33	0.00	0.00	0.00	0.00	0.00	0.00	0.00	435.33	0.50	28.22
582	2,086.83	242.10	0.00	102.02	0.00	98.67	124.35	38.69	1,481.00	75.25	3,992.35
586	426.02	0.00	21.48	189.14	32.46	182.94	0.00	0.00	0.00	0.00	0.00
651	0.00	0.00	0.00	0.00	0.00	0.00	0.00	0.00	0.00	3.00	183.06
657	0.00	0.00	0.00	0.00	0.00	0.00	0.00	0.00	0.00	2.00	122.04
726	0.00	0.00	0.00	0.00	0.00	0.00	0.00	0.00	0.00	17.00	343.24
727	225.34	0.00	0.00	106.40	16.03	102.91	0.00	0.00	0.00	127.50	2,425.41
728	0.00	0.00	0.00	0.00	0.00	0.00	0.00	0.00	0.00	115.25	2,225.48
730	80.00	0.00	0.00	0.00	0.00	0.00	0.00	0.00	80.00	43.75	990.07
731	0.00	0.00	0.00	0.00	0.00	0.00	0.00	0.00	0.00	15.75	301.76
732	0.00	0.00	0.00	0.00	0.00	0.00	0.00	0.00	0.00	76.25	1,545.55
735	481.67	0.00	0.00	0.00	0.00	0.00	0.00	0.00	481.67	42.00	799.67
736	0.00	0.00	0.00	0.00	0.00	0.00	0.00	0.00	0.00	114.75	2,219.82
744	0.00	0.00	0.00	0.00	0.00	0.00	0.00	0.00	0.00	10.00	226.30
748	0.00	0.00	0.00	0.00	0.00	0.00	0.00	0.00	0.00	45.50	858.14
750	342.67	0.00	0.00	0.00	0.00	0.00	0.00	0.00	342.67	104.50	2,042.55
751	0.00	0.00	0.00	0.00	0.00	0.00	0.00	0.00	0.00	15.00	324.37
753	342.33	0.00	0.00	0.00	0.00	0.00	0.00	0.00	342.33	92.75	1,800.17
758	404.13	0.00	0.00	0.00	0.00	0.00	0.00	0.00	404.13	129.75	2,488.59
759	404.13	0.00	0.00	0.00	0.00	0.00	0.00	0.00	404.13	80.50	1,518.24
761	255.00	0.00	0.00	0.00	0.00	0.00	0.00	0.00	255.00	111.25	2,197.19
762	502.13	0.00	0.00	114.42	0.00	110.67	0.00	22.04	255.00	69.75	1,330.58
763	566.67	0.00	0.00	0.00	0.00	0.00	0.00	0.00	566.67	108.75	2,160.40
764	941.59	0.00	0.00	157.32	45.17	152.16	0.00	20.27	566.67	62.25	1,174.07
765	382.67	0.00	0.00	0.00	0.00	0.00	0.00	0.00	382.67	99.00	1,901.08
766	332.07	0.00	0.00	0.00	0.00	0.00	0.00	44.07	288.00	0.00	0.00
826	0.00	0.00	0.00	0.00	0.00	0.00	0.00	0.00	0.00	14.00	280.58
827	794.24	0.00	0.00	403.74	0.00	390.50	0.00	0.00	0.00	111.75	2,069.41
828	0.00	0.00	0.00	0.00	0.00	0.00	0.00	0.00	0.00	111.75	2,113.67
830	167.29	0.00	0.00	0.00	0.00	0.00	0.00	103.62	63.67	36.50	808.50
831	355.48	0.00	0.00	161.25	38.27	155.96	0.00	0.00	0.00	19.75	389.49
832	0.00	0.00	0.00	0.00	0.00	0.00	0.00	0.00	0.00	77.75	1,545.99
833	2,155.47	0.00	0.00	0.00	2,155.47	0.00	0.00	0.00	0.00	0.00	0.00
835	538.33	0.00	0.00	0.00	0.00	0.00	0.00	0.00	538.33	40.00	745.79
836	0.00	0.00	0.00	0.00	0.00	0.00	0.00	0.00	0.00	117.25	2,217.03
844	0.00	0.00	0.00	0.00	0.00	0.00	0.00	0.00	0.00	16.00	354.40
848	1,822.77	0.00	67.74	880.73	0.00	851.86	0.00	22.44	0.00	44.75	829.80
850	324.64	0.00	0.00	0.00	33.31	0.00	0.00	0.00	291.33	91.00	1,703.89
851	0.00	0.00	0.00	0.00	0.00	0.00	0.00	0.00	0.00	15.00	317.49
853	426.40	0.00	0.00	57.21	22.53	55.33	0.00	0.00	291.33	84.75	1,606.94
856	0.00	0.00	0.00	0.00	0.00	0.00	0.00	0.00	0.00	4.25	238.00
857	0.00	0.00	0.00	0.00	0.00	0.00	0.00	0.00	0.00	8.00	448.00
858	386.21	0.00	0.00	0.00	33.31	0.00	0.00	0.00	352.90	131.75	2,467.19
859	812.67	0.00	77.42	171.62	24.47	165.99	0.00	20.27	352.90	87.50	1,615.26
861	593.42	0.00	0.00	114.42	0.00	110.67	0.00	0.00	368.33	109.25	2,109.04
862	368.33	0.00	0.00	0.00	0.00	0.00	0.00	0.00	368.33	82.75	1,542.34
863	543.31	0.00	0.00	0.00	33.31	0.00	0.00	0.00	510.00	102.50	1,987.22
864	510.00	0.00	0.00	0.00	0.00	0.00	0.00	0.00	510.00	103.50	1,910.67
865	496.00	0.00	0.00	0.00	0.00	0.00	0.00	0.00	496.00	91.00	1,711.23
866	372.00	0.00	0.00	0.00	0.00	0.00	0.00	0.00	372.00	0.00	0.00
890	793.79	0.00	0.00	0.00	0.00	0.00	0.00	0.00	793.79	0.50	167.68
926	0.00	0.00	0.00	0.00	0.00	0.00	0.00	0.00	0.00	10.00	184.60
927	0.00	0.00	0.00	0.00	0.00	0.00	0.00	0.00	0.00	59.50	1,112.26

1/1/2026 Thru 4/30/2026 ( 4 MONTHS EST DPRN ) (ALL WO TYPES) (ALL WO KINDS)

<u>Equipment</u>	<u>Total-cost</u>	<u>Fuel</u>	<u>Lube</u>	<u>Lab+fben</u>	<u>Part</u>	<u>Overhead</u>	<u>Tire/batt</u>	<u>Sundry</u>	<u>Dprn-mnthly</u>	<u>Units</u>	<u>Revenue</u>
928	0.00	0.00	0.00	0.00	0.00	0.00	0.00	0.00	0.00	50.75	936.86
930	7.29	0.00	0.00	0.00	7.29	0.00	0.00	0.00	0.00	0.00	0.00
930V	402.07	0.00	0.00	0.00	0.00	0.00	0.00	0.00	402.07	9.25	405.27
931	264.82	0.00	0.00	114.42	39.73	110.67	0.00	0.00	0.00	35.25	734.72
932	0.00	0.00	0.00	0.00	0.00	0.00	0.00	0.00	0.00	36.50	785.46
933	0.00	0.00	0.00	0.00	0.00	0.00	0.00	0.00	0.00	2.00	36.92
935	425.00	0.00	0.00	0.00	0.00	0.00	0.00	0.00	425.00	17.75	331.36
936	0.00	0.00	0.00	0.00	0.00	0.00	0.00	0.00	0.00	75.75	1,416.83
944	0.00	0.00	0.00	0.00	0.00	0.00	0.00	0.00	0.00	6.00	132.90
948	0.00	0.00	0.00	0.00	0.00	0.00	0.00	0.00	0.00	40.25	750.43
950	0.00	0.00	0.00	0.00	0.00	0.00	0.00	0.00	0.00	60.25	1,159.34
951	0.00	0.00	0.00	0.00	0.00	0.00	0.00	0.00	0.00	10.50	219.66
953	58.33	0.00	0.00	0.00	0.00	0.00	0.00	0.00	58.33	39.50	758.71
958	747.63	0.00	0.00	207.30	0.00	200.50	0.00	0.00	339.83	57.00	1,061.49
959	939.16	0.00	0.00	0.00	599.33	0.00	0.00	0.00	339.83	49.00	904.54
961	371.87	0.00	0.00	0.00	0.00	0.00	0.00	0.00	371.87	44.25	845.49
962	371.87	0.00	0.00	0.00	0.00	0.00	0.00	0.00	371.87	31.25	576.88
963	1,444.23	0.00	0.00	286.04	633.53	276.66	0.00	0.00	248.00	57.25	1,080.85
963C	469.00	0.00	0.00	0.00	0.00	0.00	0.00	0.00	469.00	10.00	184.63
964	248.00	0.00	0.00	0.00	0.00	0.00	0.00	0.00	248.00	35.00	646.12
965	389.67	0.00	0.00	0.00	0.00	0.00	0.00	0.00	389.67	75.50	1,405.73
966	233.67	0.00	0.00	0.00	0.00	0.00	0.00	0.00	233.67	0.00	0.00
<b>(24) GREE</b>	<b>365,687.61</b>	<b>63,700.54</b>	<b>4,455.55</b>	<b>43,806.38</b>	<b>51,772.06</b>	<b>42,148.59</b>	<b>7,677.83</b>	<b>6,127.71</b>	<b>145,998.95</b>	<b>28,994.50</b>	<b>506,724.84</b>
<b>(4) NORTI</b>	<b>365,687.61</b>	<b>63,700.54</b>	<b>4,455.55</b>	<b>43,806.38</b>	<b>51,772.06</b>	<b>42,148.59</b>	<b>7,677.83</b>	<b>6,127.71</b>	<b>145,998.95</b>	<b>28,994.50</b>	<b>506,724.84</b>

Rows Processed 182

Show all data where the DOT\_RGN\_CD matches one of the values in this list 4  
and the DOT\_CNTY\_CD matches one of the values in this list 24  
and the USER\_ID matches one of the values in this list 24BPENCE  
and the WKST\_ADDR matches one of the values in this list MDC33755790  
and the CHEMS\_EQP\_ID matches one of the values in this list 002,003,004,005,006,007,008,009,013,015,016,017,018,019,024,025,026,027,028,030,031,032,033,035,036,037,040,04  
2,044,045,048,050,051,052,053,058,059,061,062,063,064,065,066,1000,1001,101,102,1020,1021,1026,1027,1028,103,1031,1032,1033,1035,1036,1044,1045,1048,1050,1051,1052,105  
3,1058,1059,1061,1062,1063,1064,1065,1066,110R,110S,111R,111S,112R,112S,113R,113S,114R,114S,115,130,133,134,136,138,139,142,143,193,194,195,196,197,197C,197G,200,2  
06,207,208,209,210,211,212,216,221,225,303,304,305,308,310,311,312,313,314,323,326,334,336,337,356,420,432,436,455,456,457,458,459,500,501,561,570,571,572,573,574,575,57  
6,577,578,579,581,582,586,651,655,657,720,726,727,728,730,731,732,733,735,736,744,745,747,748,750,751,752,753,754R,758,759,760,761,762,763,764,765,766,820,826,827,828,83  
0,831,832,833,835,836,838,842,844,845,848,850,851,852,853,856,857,858,859,861,862,863,864,865,866,886,890,920,926,927,928,928C,930,930V,931,932,933,933C,935,936,938,942  
,944,945,948,950,951,952,953,958,959,960,961,962,963,963C,964,965,966

Revenue Summary

Finance Committee-Sum-Expenditure

GREEN LAKE COUNTY

Report Description: 100

Account Year: 26

Period Range: 01 - 04

Date Range: 01/01/2026 - 04/30/2026

Account	Account Description	Original Budget	Adjustments	Est Revenue	Revenue Received		Available	Percent
					Current	YTD		
26 CALENDAR YEAR 2026								
211 County Roads and Bridges								
41110 General Property Taxes								
26-211-29-41110-000-000	General Property Taxes	2,473,663.00	0.00	2,473,663.00	2,473,663.00	2,473,663.00	0.00	0.00
<b>41110 General Property Taxes</b>		<b>\$2,473,663.00</b>	<b>\$0.00</b>	<b>\$2,473,663.00</b>	<b>\$2,473,663.00</b>	<b>\$2,473,663.00</b>	<b>\$0.00</b>	<b>0.00</b>
43531 C.T.H.S. Revenue from State								
26-211-29-43531-000-000	CTH's Revenue from State	1,391,000.00	0.00	1,391,000.00	588,479.94	588,479.94	802,520.06	57.69
<b>43531 C.T.H.S. Revenue from State</b>		<b>\$1,391,000.00</b>	<b>\$0.00</b>	<b>\$1,391,000.00</b>	<b>\$588,479.94</b>	<b>\$588,479.94</b>	<b>\$802,520.06</b>	<b>57.69</b>
49300 Applied General Funds								
26-211-29-49300-000-000	TRANSFER FROM DEBT SERVICE FUND	1,250,000.00	0.00	1,250,000.00	0.00	0.00	1,250,000.00	100.00
<b>49300 Applied General Funds</b>		<b>\$1,250,000.00</b>	<b>\$0.00</b>	<b>\$1,250,000.00</b>	<b>\$0.00</b>	<b>\$0.00</b>	<b>\$1,250,000.00</b>	<b>100.00</b>
<b>29 Highway</b>		<b>\$5,114,663.00</b>	<b>\$0.00</b>	<b>\$5,114,663.00</b>	<b>\$3,062,142.94</b>	<b>\$3,062,142.94</b>	<b>\$2,052,520.06</b>	<b>40.13</b>
<b>211 County Roads and Bridges</b>		<b>\$5,114,663.00</b>	<b>\$0.00</b>	<b>\$5,114,663.00</b>	<b>\$3,062,142.94</b>	<b>\$3,062,142.94</b>	<b>\$2,052,520.06</b>	<b>40.13</b>

Revenue Summary

Finance Committee-Sum-Expenditure

GREEN LAKE COUNTY

Report Description: 100

Account Year: 26

Period Range: 01 - 04

Date Range: 01/01/2026 - 04/30/2026

Account	Account Description	Original Budget	Adjustments	Est Revenue	Revenue Received		Available	Percent
					Current	YTD		
26 CALENDAR YEAR 2026								
701 Highway								
44201 Off Pavement Utility Fee								
26-701-29-44201-000-000	Off Pavement Utility Fee	10,350.00	0.00	10,350.00	350.00	350.00	10,000.00	96.62
<b>44201 Off Pavement Utility Fee</b>		<b>\$10,350.00</b>	<b>\$0.00</b>	<b>\$10,350.00</b>	<b>\$350.00</b>	<b>\$350.00</b>	<b>\$10,000.00</b>	<b>96.62</b>
44205 Driveway								
26-701-29-44205-000-000	Driveway/Variance	2,040.00	0.00	2,040.00	750.00	750.00	1,290.00	63.24
<b>44205 Driveway</b>		<b>\$2,040.00</b>	<b>\$0.00</b>	<b>\$2,040.00</b>	<b>\$750.00</b>	<b>\$750.00</b>	<b>\$1,290.00</b>	<b>63.24</b>
44260 Oversize								
26-701-29-44260-000-000	Oversize/Overweight Permits	550.00	0.00	550.00	225.00	225.00	325.00	59.09
<b>44260 Oversize</b>		<b>\$550.00</b>	<b>\$0.00</b>	<b>\$550.00</b>	<b>\$225.00</b>	<b>\$225.00</b>	<b>\$325.00</b>	<b>59.09</b>
44261 Overweight								
26-701-29-44261-000-000	Multi-Trip Permits	3,000.00	0.00	3,000.00	2,700.00	2,700.00	300.00	10.00
<b>44261 Overweight</b>		<b>\$3,000.00</b>	<b>\$0.00</b>	<b>\$3,000.00</b>	<b>\$2,700.00</b>	<b>\$2,700.00</b>	<b>\$300.00</b>	<b>10.00</b>
47231 Routine Maintenance								
26-701-29-47231-000-000	Routine Maintenance	412,751.00	0.00	412,751.00	79,690.00	79,690.00	333,061.00	80.69
<b>47231 Routine Maintenance</b>		<b>\$412,751.00</b>	<b>\$0.00</b>	<b>\$412,751.00</b>	<b>\$79,690.00</b>	<b>\$79,690.00</b>	<b>\$333,061.00</b>	<b>80.69</b>
47239 Other - Sup. R & R-Radio-GPL etc.								
26-701-29-47239-000-000	Other - Sup. R&R-Radio-GPL etc	204,922.00	0.00	204,922.00	66,451.53	66,451.53	138,470.47	67.57
<b>47239 Other - Sup. R &amp; R-Radio-GPL etc.</b>		<b>\$204,922.00</b>	<b>\$0.00</b>	<b>\$204,922.00</b>	<b>\$66,451.53</b>	<b>\$66,451.53</b>	<b>\$138,470.47</b>	<b>67.57</b>
47292 State - Admin								
26-701-29-47292-000-000	State - Admin	24,100.00	0.00	24,100.00	5,001.40	5,001.40	19,098.60	79.25
<b>47292 State - Admin</b>		<b>\$24,100.00</b>	<b>\$0.00</b>	<b>\$24,100.00</b>	<b>\$5,001.40</b>	<b>\$5,001.40</b>	<b>\$19,098.60</b>	<b>79.25</b>
47300 Other Local Governments								
26-701-29-47300-000-000	Cities, Villages, Towns, Cty.	546,424.00	0.00	546,424.00	-118,800.95	-118,800.95	665,224.95	121.74
<b>47300 Other Local Governments</b>		<b>\$546,424.00</b>	<b>\$0.00</b>	<b>\$546,424.00</b>	<b>-\$118,800.95</b>	<b>-\$118,800.95</b>	<b>\$665,224.95</b>	<b>121.74</b>
47392 Local - Admin Charges								
26-701-29-47392-000-000	Local - Admin Charges	23,824.00	0.00	23,824.00	2,413.33	2,413.33	21,410.67	89.87
<b>47392 Local - Admin Charges</b>		<b>\$23,824.00</b>	<b>\$0.00</b>	<b>\$23,824.00</b>	<b>\$2,413.33</b>	<b>\$2,413.33</b>	<b>\$21,410.67</b>	<b>89.87</b>
47410 Interdepartment Invoicing								
26-701-29-47410-000-000	Interdepartmental Invoicing	131,488.00	0.00	131,488.00	1,495.56	1,495.56	129,992.44	98.86
<b>47410 Interdepartment Invoicing</b>		<b>\$131,488.00</b>	<b>\$0.00</b>	<b>\$131,488.00</b>	<b>\$1,495.56</b>	<b>\$1,495.56</b>	<b>\$129,992.44</b>	<b>98.86</b>
47430 Charges for Services - CTHS								
26-701-29-47430-000-000	Charges for Services - CTH's	5,024,902.00	0.00	5,024,902.00	886,265.14	886,265.14	4,138,636.86	82.36
<b>47430 Charges for Services - CTHS</b>		<b>\$5,024,902.00</b>	<b>\$0.00</b>	<b>\$5,024,902.00</b>	<b>\$886,265.14</b>	<b>\$886,265.14</b>	<b>\$4,138,636.86</b>	<b>82.36</b>
47492 CTHS - Admin								
26-701-29-47492-000-000	CTH's - Admin	219,086.00	0.00	219,086.00	40,376.00	40,376.00	178,710.00	81.57
<b>47492 CTHS - Admin</b>		<b>\$219,086.00</b>	<b>\$0.00</b>	<b>\$219,086.00</b>	<b>\$40,376.00</b>	<b>\$40,376.00</b>	<b>\$178,710.00</b>	<b>81.57</b>
48000 Miscellaneous Revenues								
26-701-29-48000-000-000	Miscellaneous Revenues	2,000.00	0.00	2,000.00	0.00	0.00	2,000.00	100.00
<b>48000 Miscellaneous Revenues</b>		<b>\$2,000.00</b>	<b>\$0.00</b>	<b>\$2,000.00</b>	<b>\$0.00</b>	<b>\$0.00</b>	<b>\$2,000.00</b>	<b>100.00</b>
48100 Interest on Temporary Investments								
26-701-29-48100-000-000	Interest Income - HWY	0.00	0.00	0.00	238,008.16	238,008.16	-238,008.16	0.00
<b>48100 Interest on Temporary Investments</b>		<b>\$0.00</b>	<b>\$0.00</b>	<b>\$0.00</b>	<b>\$238,008.16</b>	<b>\$238,008.16</b>	<b>-\$238,008.16</b>	<b>0.00</b>
48400 Insurance Claims & Refunds								
26-701-29-48400-000-000	Insurance Recoveries	2,000.00	0.00	2,000.00	151.07	151.07	1,848.93	92.45
<b>48400 Insurance Claims &amp; Refunds</b>		<b>\$2,000.00</b>	<b>\$0.00</b>	<b>\$2,000.00</b>	<b>\$151.07</b>	<b>\$151.07</b>	<b>\$1,848.93</b>	<b>92.45</b>

Report Description: 100

Account Year: 26

Period Range: 01 - 04

Date Range: 01/01/2026 - 04/30/2026

Account	Account Description	Original Budget	Adjustments	Est Revenue	Revenue Received		Available	Percent
					Current	YTD		
26 CALENDAR YEAR 2026								
701 Highway								
48440 Revenue from Cost of Sales								
26-701-29-48440-000-000	Revenue from Cost of Sales	20,000.00	0.00	20,000.00	9,330.82	9,330.82	10,669.18	53.35
<b>48440 Revenue from Cost of Sales</b>		<b>\$20,000.00</b>	<b>\$0.00</b>	<b>\$20,000.00</b>	<b>\$9,330.82</b>	<b>\$9,330.82</b>	<b>\$10,669.18</b>	<b>53.35</b>
49101 Contribution by County								
26-701-29-49101-000-000	Contribution by County	150,790.00	0.00	150,790.00	0.00	0.00	150,790.00	100.00
<b>49101 Contribution by County</b>		<b>\$150,790.00</b>	<b>\$0.00</b>	<b>\$150,790.00</b>	<b>\$0.00</b>	<b>\$0.00</b>	<b>\$150,790.00</b>	<b>100.00</b>
<b>29 Highway</b>		<b>\$6,778,227.00</b>	<b>\$0.00</b>	<b>\$6,778,227.00</b>	<b>\$1,214,407.06</b>	<b>\$1,214,407.06</b>	<b>\$5,563,819.94</b>	<b>82.08</b>
<b>701 Highway</b>		<b>\$6,778,227.00</b>	<b>\$0.00</b>	<b>\$6,778,227.00</b>	<b>\$1,214,407.06</b>	<b>\$1,214,407.06</b>	<b>\$5,563,819.94</b>	<b>82.08</b>
<b>26 CALENDAR YEAR 2026</b>		<b>\$11,892,890.00</b>	<b>\$0.00</b>	<b>\$11,892,890.00</b>	<b>\$4,276,550.00</b>	<b>\$4,276,550.00</b>	<b>\$7,616,340.00</b>	<b>64.04</b>

**Expenditure Summary**

**Finance Committee-Sum-Expenditure**

GREEN LAKE COUNTY

Report Description: 100 Account Year: 26 Account Period Range: 01 - 04 Date Range: 01/01/2026 - 04/30/2026

Account	Original Budget	Adjustments	Adjusted Budget	Encumbrances Current	YTD	Expenditures Current	YTD	Available	Percent
<b>Account Description</b>									
<b>26 CALENDAR YEAR 2026</b>									
<b>211 County Roads and Bridges</b>									
<b>53309 County Supervision</b>									
26-211-29-53309-219-000 County Supervision	172,099.00	0.00	172,099.00	0.00	0.00	51,900.41	51,900.41	120,198.59	69.84
<b>53309 County Supervision</b>	<b>\$172,099.00</b>	<b>\$0.00</b>	<b>\$172,099.00</b>	<b>\$0.00</b>	<b>\$0.00</b>	<b>\$51,900.41</b>	<b>\$51,900.41</b>	<b>\$120,198.59</b>	<b>69.84</b>
<b>53310 General Mtn. C.T.H's</b>									
26-211-29-53310-219-000 General Maintenance - CTH's	1,043,589.00	0.00	1,043,589.00	0.00	0.00	300,848.61	300,848.61	742,740.39	71.17
<b>53310 General Mtn. C.T.H's</b>	<b>\$1,043,589.00</b>	<b>\$0.00</b>	<b>\$1,043,589.00</b>	<b>\$0.00</b>	<b>\$0.00</b>	<b>\$300,848.61</b>	<b>\$300,848.61</b>	<b>\$742,740.39</b>	<b>71.17</b>
<b>53311 C.T.H's Winter Mtn.</b>									
26-211-29-53311-219-000 Winter Maintenance - CTH's	614,919.00	0.00	614,919.00	0.00	0.00	411,860.55	411,860.55	203,058.45	33.02
<b>53311 C.T.H's Winter Mtn.</b>	<b>\$614,919.00</b>	<b>\$0.00</b>	<b>\$614,919.00</b>	<b>\$0.00</b>	<b>\$0.00</b>	<b>\$411,860.55</b>	<b>\$411,860.55</b>	<b>\$203,058.45</b>	<b>33.02</b>
<b>53312 C.T.H's Bridge Mtn &amp; Insp CTH's</b>									
26-211-29-53312-219-000 Bridge Maintenance & Inspection - CTH's	7,931.00	0.00	7,931.00	0.00	0.00	0.00	0.00	7,931.00	100.00
<b>53312 C.T.H's Bridge Mtn &amp; Insp CTH's</b>	<b>\$7,931.00</b>	<b>\$0.00</b>	<b>\$7,931.00</b>	<b>\$0.00</b>	<b>\$0.00</b>	<b>\$0.00</b>	<b>\$0.00</b>	<b>\$7,931.00</b>	<b>100.00</b>
<b>53313 Reconstruction</b>									
26-211-29-53313-219-000 Reconstruction - CTH's	2,947,229.00	0.00	2,947,229.00	0.00	0.00	162,031.59	162,031.59	2,785,197.41	94.50
<b>53313 Reconstruction</b>	<b>\$2,947,229.00</b>	<b>\$0.00</b>	<b>\$2,947,229.00</b>	<b>\$0.00</b>	<b>\$0.00</b>	<b>\$162,031.59</b>	<b>\$162,031.59</b>	<b>\$2,785,197.41</b>	<b>94.50</b>
<b>53315 Chip Seal Coat</b>									
26-211-29-53315-219-000 Chip Seal Coat	298,896.00	0.00	298,896.00	0.00	0.00	0.00	0.00	298,896.00	100.00
<b>53315 Chip Seal Coat</b>	<b>\$298,896.00</b>	<b>\$0.00</b>	<b>\$298,896.00</b>	<b>\$0.00</b>	<b>\$0.00</b>	<b>\$0.00</b>	<b>\$0.00</b>	<b>\$298,896.00</b>	<b>100.00</b>
<b>53591 Railroad</b>									
26-211-29-53591-000-000 Railroad Consortium	30,000.00	0.00	30,000.00	0.00	0.00	30,000.00	30,000.00	0.00	0.00
<b>53591 Railroad</b>	<b>\$30,000.00</b>	<b>\$0.00</b>	<b>\$30,000.00</b>	<b>\$0.00</b>	<b>\$0.00</b>	<b>\$30,000.00</b>	<b>\$30,000.00</b>	<b>\$0.00</b>	<b>0.00</b>
<b>29 Highway</b>	<b>\$5,114,663.00</b>	<b>\$0.00</b>	<b>\$5,114,663.00</b>	<b>\$0.00</b>	<b>\$0.00</b>	<b>\$956,641.16</b>	<b>\$956,641.16</b>	<b>\$4,158,021.84</b>	<b>81.30</b>
<b>211 County Roads and Bridges</b>	<b>\$5,114,663.00</b>	<b>\$0.00</b>	<b>\$5,114,663.00</b>	<b>\$0.00</b>	<b>\$0.00</b>	<b>\$956,641.16</b>	<b>\$956,641.16</b>	<b>\$4,158,021.84</b>	<b>81.30</b>

**Expenditure Summary**

**Finance Committee-Sum-Expenditure**

GREEN LAKE COUNTY

Report Description: 100 Account Year: 26 Account Period Range: 01 - 04 Date Range: 01/01/2026 - 04/30/2026

Account	Original Budget	Adjustments	Adjusted Budget	Encumbrances Current	YTD	Expenditures Current	YTD	Available	Percent
<b>Account Description</b>									
<b>26 CALENDAR YEAR 2026</b>									
<b>701 Highway</b>									
<b>53110 Highway Administration</b>									
26-701-29-53110-110-000 Salaries	232,417.00	0.00	232,417.00	0.00	0.00	58,995.03	58,995.03	173,421.97	74.62
26-701-29-53110-120-000 Wages	600.00	0.00	600.00	0.00	0.00	257.20	257.20	342.80	57.13
26-701-29-53110-125-000 Overtime	7,000.00	0.00	7,000.00	0.00	0.00	5,945.86	5,945.86	1,054.14	15.06
26-701-29-53110-130-000 Employee Benefits	128,601.00	0.00	128,601.00	0.00	0.00	39,307.93	39,307.93	89,293.07	69.43
26-701-29-53110-213-000 Accounting & Auditing	1,893.00	0.00	1,893.00	0.00	0.00	0.00	0.00	1,893.00	100.00
26-701-29-53110-225-000 Telephone	2,202.00	0.00	2,202.00	0.00	0.00	586.10	586.10	1,615.90	73.38
26-701-29-53110-242-000 Print Management	300.00	0.00	300.00	0.00	0.00	78.87	78.87	221.13	73.71
26-701-29-53110-310-000 Office Supplies	3,989.00	0.00	3,989.00	0.00	0.00	1,556.80	1,556.80	2,432.20	60.97
26-701-29-53110-311-000 Postage	350.00	0.00	350.00	0.00	0.00	110.78	110.78	239.22	68.35
26-701-29-53110-320-000 Publications	1,200.00	0.00	1,200.00	0.00	0.00	185.00	185.00	1,015.00	84.58
26-701-29-53110-325-000 Registrations & Conventions	840.00	0.00	840.00	0.00	0.00	651.00	651.00	189.00	22.50
26-701-29-53110-329-000 Publications	0.00	0.00	0.00	0.00	0.00	462.00	462.00	-462.00	0.00
26-701-29-53110-336-000 Lodging	594.00	0.00	594.00	0.00	0.00	101.00	101.00	493.00	83.00
26-701-29-53110-350-000 Repair & Maintenance	5,108.00	0.00	5,108.00	0.00	0.00	2,585.87	2,585.87	2,522.13	49.38
26-701-29-53110-532-000 Building & Grounds Allocation	6,817.00	0.00	6,817.00	0.00	0.00	0.00	0.00	6,817.00	100.00
<b>53110 Highway Administration</b>	<b>\$391,911.00</b>	<b>\$0.00</b>	<b>\$391,911.00</b>	<b>\$0.00</b>	<b>\$0.00</b>	<b>\$110,823.44</b>	<b>\$110,823.44</b>	<b>\$281,087.56</b>	<b>71.72</b>
<b>53191 Supervision</b>									
26-701-29-53191-000-000 Supervision	1,291.00	0.00	1,291.00	0.00	0.00	0.00	0.00	1,291.00	100.00
26-701-29-53191-110-000 Salaries	88,628.00	0.00	88,628.00	0.00	0.00	28,548.71	28,548.71	60,079.29	67.79
26-701-29-53191-120-000 Wages	100.00	0.00	100.00	0.00	0.00	26.77	26.77	73.23	73.23
26-701-29-53191-130-000 Employee Benefits	47,540.00	0.00	47,540.00	0.00	0.00	17,228.16	17,228.16	30,311.84	63.76
26-701-29-53191-225-000 Telephone	1,386.00	0.00	1,386.00	0.00	0.00	253.04	253.04	1,132.96	81.74

**Expenditure Summary**

**Finance Committee-Sum-Expenditure**

GREEN LAKE COUNTY

Report Description: 100 Account Year: 26 Account Period Range: 01 - 04 Date Range: 01/01/2026 - 04/30/2026

Account Account Description	Original Budget	Adjustments	Adjusted Budget	Encumbrances		Expenditures		Available	Percent
				Current	YTD	Current	YTD		
<b>26 CALENDAR YEAR 2026</b>									
<b>701 Highway</b>									
<b>53191 Supervision</b>									
26-701-29-53191-325-000 Registrations & Conventions	465.00	0.00	465.00	0.00	0.00	0.00	0.00	465.00	100.00
26-701-29-53191-350-000 Repair & Maintenance	4,700.00	0.00	4,700.00	0.00	0.00	1,661.62	1,661.62	3,038.38	64.65
26-701-29-53191-534-000 Machinery Rental	19,407.00	0.00	19,407.00	0.00	0.00	7,701.18	7,701.18	11,705.82	60.32
<b>53191 Supervision</b>	<b>\$163,517.00</b>	<b>\$0.00</b>	<b>\$163,517.00</b>	<b>\$0.00</b>	<b>\$0.00</b>	<b>\$55,419.48</b>	<b>\$55,419.48</b>	<b>\$108,097.52</b>	<b>66.11</b>
<b>53192 Radio Expenses</b>									
26-701-29-53192-206-000 Maintenance Contracts	2,055.00	0.00	2,055.00	0.00	0.00	342.50	342.50	1,712.50	83.33
26-701-29-53192-314-000 Small Items of Equipment	3,412.00	0.00	3,412.00	0.00	0.00	0.00	0.00	3,412.00	100.00
<b>53192 Radio Expenses</b>	<b>\$5,467.00</b>	<b>\$0.00</b>	<b>\$5,467.00</b>	<b>\$0.00</b>	<b>\$0.00</b>	<b>\$342.50</b>	<b>\$342.50</b>	<b>\$5,124.50</b>	<b>93.74</b>
<b>53193 General Public Liability</b>									
26-701-29-53193-509-000 Public Liability	29,259.00	0.00	29,259.00	0.00	0.00	0.00	0.00	29,259.00	100.00
<b>53193 General Public Liability</b>	<b>\$29,259.00</b>	<b>\$0.00</b>	<b>\$29,259.00</b>	<b>\$0.00</b>	<b>\$0.00</b>	<b>\$0.00</b>	<b>\$0.00</b>	<b>\$29,259.00</b>	<b>100.00</b>
<b>53210 Employee Taxes and Benefits Cost Pool</b>									
26-701-29-53210-110-000 Salaries	0.00	0.00	0.00	0.00	0.00	-12,827.49	-12,827.49	12,827.49	0.00
26-701-29-53210-120-000 Wages	0.00	0.00	0.00	0.00	0.00	-47,152.59	-47,152.59	47,152.59	0.00
26-701-29-53210-125-000 Overtime	0.00	0.00	0.00	0.00	0.00	8,129.81	8,129.81	-8,129.81	0.00
26-701-29-53210-131-000 Sick Leave Pay	0.00	0.00	0.00	0.00	0.00	13,780.43	13,780.43	-13,780.43	0.00
26-701-29-53210-132-000 Vacation Pay	0.00	0.00	0.00	0.00	0.00	18,575.64	18,575.64	-18,575.64	0.00
26-701-29-53210-134-000 Holiday Pay	0.00	0.00	0.00	0.00	0.00	14,075.00	14,075.00	-14,075.00	0.00
26-701-29-53210-135-000 Floating Holiday	0.00	0.00	0.00	0.00	0.00	6,281.94	6,281.94	-6,281.94	0.00
26-701-29-53210-137-100 Comp-Accumulated	0.00	0.00	0.00	0.00	0.00	-13,620.76	-13,620.76	13,620.76	0.00
26-701-29-53210-137-300 Comp - Use	0.00	0.00	0.00	0.00	0.00	5,953.59	5,953.59	-5,953.59	0.00
26-701-29-53210-138-000 Other - leave with pay	0.00	0.00	0.00	0.00	0.00	1,923.40	1,923.40	-1,923.40	0.00
26-701-29-53210-151-000 Social Security	0.00	0.00	0.00	0.00	0.00	31,528.62	31,528.62	-31,528.62	0.00

**Expenditure Summary**

**Finance Committee-Sum-Expenditure**

GREEN LAKE COUNTY

Report Description: 100 Account Year: 26 Account Period Range: 01 - 04 Date Range: 01/01/2026 - 04/30/2026

Account			Encumbrances		Expenditures		Available	Percent		
	Original Budget	Adjustments	Adjusted Budget	Current	YTD	Current			YTD	
<b>Account Description</b>										
<b>26 CALENDAR YEAR 2026</b>										
<b>701 Highway</b>										
<b>53210 Employee Taxes and Benefits Cost Pool</b>										
26-701-29-53210-153-000	0.00	0.00	0.00	0.00	0.00	0.00	30,850.41	30,850.41	-30,850.41	0.00
Ret. Employer Share										
26-701-29-53210-154-000	0.00	0.00	0.00	0.00	0.00	0.00	97,236.22	97,236.22	-97,236.22	0.00
Health Insurance										
26-701-29-53210-155-000	0.00	0.00	0.00	0.00	0.00	0.00	1,256.24	1,256.24	-1,256.24	0.00
Life Insurance										
26-701-29-53210-910-000	0.00	0.00	0.00	0.00	0.00	0.00	-261,290.89	-261,290.89	261,290.89	0.00
Employee Taxes & Benefits										
<b>53210 Employee Taxes and Benefits Cost Pool</b>	<b>\$0.00</b>	<b>\$0.00</b>	<b>\$0.00</b>	<b>\$0.00</b>	<b>\$0.00</b>	<b>\$0.00</b>	<b>-\$105,300.43</b>	<b>-\$105,300.43</b>	<b>\$105,300.43</b>	<b>0.00</b>
<b>53220 Field Small Tools Cost Pool</b>										
26-701-29-53220-130-120	0.00	0.00	0.00	0.00	0.00	0.00	228.61	228.61	-228.61	0.00
Employee Benefits										
26-701-29-53220-130-121	0.00	0.00	0.00	0.00	0.00	0.00	1,020.99	1,020.99	-1,020.99	0.00
Employee Benefit										
26-701-29-53220-362-120	0.00	0.00	0.00	0.00	0.00	0.00	4,985.07	4,985.07	-4,985.07	0.00
Consumable Small Tools-Field										
26-701-29-53220-362-121	0.00	0.00	0.00	0.00	0.00	0.00	6,904.21	6,904.21	-6,904.21	0.00
Consumable Small Tools-Safety										
26-701-29-53220-362-122	0.00	0.00	0.00	0.00	0.00	0.00	90.24	90.24	-90.24	0.00
Consumable Small Tools-Traffic										
26-701-29-53220-920-000	0.00	0.00	0.00	0.00	0.00	0.00	-6,020.67	-6,020.67	6,020.67	0.00
Small Field Tools										
<b>53220 Field Small Tools Cost Pool</b>	<b>\$0.00</b>	<b>\$0.00</b>	<b>\$0.00</b>	<b>\$0.00</b>	<b>\$0.00</b>	<b>\$0.00</b>	<b>\$7,208.45</b>	<b>\$7,208.45</b>	<b>-\$7,208.45</b>	<b>0.00</b>
<b>53230 Shop Operations Cost Pool</b>										
26-701-29-53230-120-000	0.00	0.00	0.00	0.00	0.00	0.00	10,720.20	10,720.20	-10,720.20	0.00
Wages										
26-701-29-53230-125-000	0.00	0.00	0.00	0.00	0.00	0.00	9.43	9.43	-9.43	0.00
Overtime										
26-701-29-53230-130-000	0.00	0.00	0.00	0.00	0.00	0.00	6,468.88	6,468.88	-6,468.88	0.00
Employee Benefits										
26-701-29-53230-225-000	0.00	0.00	0.00	0.00	0.00	0.00	779.53	779.53	-779.53	0.00
Telephone										
26-701-29-53230-240-000	0.00	0.00	0.00	0.00	0.00	0.00	66.75	66.75	-66.75	0.00
Contracted Maintenance										
26-701-29-53230-310-000	0.00	0.00	0.00	0.00	0.00	0.00	1,207.92	1,207.92	-1,207.92	0.00
Office Supplies										
26-701-29-53230-314-000	0.00	0.00	0.00	0.00	0.00	0.00	2,070.19	2,070.19	-2,070.19	0.00
Small Items of Equipment										
26-701-29-53230-340-000	0.00	0.00	0.00	0.00	0.00	0.00	1,666.77	1,666.77	-1,666.77	0.00
Operating Supplies										

**Expenditure Summary**

**Finance Committee-Sum-Expenditure**

GREEN LAKE COUNTY

Report Description: 100 Account Year: 26 Account Period Range: 01 - 04 Date Range: 01/01/2026 - 04/30/2026

Account	Original Budget	Adjustments	Adjusted Budget	Encumbrances Current	YTD	Expenditures Current	YTD	Available	Percent	
<b>Account Description</b>										
<b>26 CALENDAR YEAR 2026</b>										
<b>701 Highway</b>										
<b>53230 Shop Operations Cost Pool</b>										
26-701-29-53230-345-000 Shop Supplies	0.00	0.00	0.00	0.00	0.00	0.00	7,871.54	7,871.54	-7,871.54	0.00
26-701-29-53230-350-000 Repair & Maintenance	0.00	0.00	0.00	0.00	0.00	0.00	745.08	745.08	-745.08	0.00
26-701-29-53230-534-000 Machinery Rental	0.00	0.00	0.00	0.00	0.00	0.00	1,886.56	1,886.56	-1,886.56	0.00
<b>53230 Shop Operations Cost Pool</b>	<b>\$0.00</b>	<b>\$0.00</b>	<b>\$0.00</b>	<b>\$0.00</b>	<b>\$0.00</b>	<b>\$0.00</b>	<b>\$33,492.85</b>	<b>\$33,492.85</b>	<b>-\$33,492.85</b>	<b>0.00</b>
<b>53232 Fuel Handling Cost Pool</b>										
26-701-29-53232-120-000 Wages	0.00	0.00	0.00	0.00	0.00	0.00	26.77	26.77	-26.77	0.00
26-701-29-53232-130-000 Employee Benefits	0.00	0.00	0.00	0.00	0.00	0.00	16.14	16.14	-16.14	0.00
26-701-29-53232-225-000 Telephone	0.00	0.00	0.00	0.00	0.00	0.00	505.17	505.17	-505.17	0.00
26-701-29-53232-350-000 Repair & Maintenance	0.00	0.00	0.00	0.00	0.00	0.00	2,874.71	2,874.71	-2,874.71	0.00
26-701-29-53232-534-000 Machinery Rental	0.00	0.00	0.00	0.00	0.00	0.00	20.27	20.27	-20.27	0.00
26-701-29-53232-931-000 Fuel Handling Revenue	0.00	0.00	0.00	0.00	0.00	0.00	-5,448.64	-5,448.64	5,448.64	0.00
<b>53232 Fuel Handling Cost Pool</b>	<b>\$0.00</b>	<b>\$0.00</b>	<b>\$0.00</b>	<b>\$0.00</b>	<b>\$0.00</b>	<b>\$0.00</b>	<b>-\$2,005.58</b>	<b>-\$2,005.58</b>	<b>\$2,005.58</b>	<b>0.00</b>
<b>53240 Machinery Operating Cost Pool</b>										
26-701-29-53240-120-000 Wages	0.00	0.00	0.00	0.00	0.00	0.00	27,347.84	27,347.84	-27,347.84	0.00
26-701-29-53240-125-000 Overtime	0.00	0.00	0.00	0.00	0.00	0.00	338.60	338.60	-338.60	0.00
26-701-29-53240-130-000 Employee Benefits	0.00	0.00	0.00	0.00	0.00	0.00	16,692.17	16,692.17	-16,692.17	0.00
26-701-29-53240-350-000 Repair & Maintenance	0.00	0.00	0.00	0.00	0.00	0.00	122,551.37	122,551.37	-122,551.37	0.00
26-701-29-53240-534-000 Machinery Rental	0.00	0.00	0.00	0.00	0.00	0.00	6,410.88	6,410.88	-6,410.88	0.00
26-701-29-53240-940-000 Mach. Operation Rev.	-739,438.00	0.00	-739,438.00	0.00	0.00	0.00	-506,372.97	-506,372.97	-233,065.03	0.00
<b>53240 Machinery Operating Cost Pool</b>	<b>-\$739,438.00</b>	<b>\$0.00</b>	<b>-\$739,438.00</b>	<b>\$0.00</b>	<b>\$0.00</b>	<b>\$0.00</b>	<b>-\$333,032.11</b>	<b>-\$333,032.11</b>	<b>-\$406,405.89</b>	<b>0.00</b>
<b>53270 Buildings &amp; Ground Operations Cost Pool</b>										
26-701-29-53270-120-000 Wages	0.00	0.00	0.00	0.00	0.00	0.00	4,614.35	4,614.35	-4,614.35	0.00
26-701-29-53270-125-000 Overtime	0.00	0.00	0.00	0.00	0.00	0.00	47.16	47.16	-47.16	0.00

**Expenditure Summary**

**Finance Committee-Sum-Expenditure**

GREEN LAKE COUNTY

Report Description: 100 Account Year: 26 Account Period Range: 01 - 04 Date Range: 01/01/2026 - 04/30/2026

Account	Original Budget	Adjustments	Adjusted Budget	Encumbrances Current	YTD	Expenditures Current	YTD	Available	Percent	
<b>Account Description</b>										
<b>26 CALENDAR YEAR 2026</b>										
<b>701 Highway</b>										
<b>53270 Buildings &amp; Ground Operations Cost Pool</b>										
26-701-29-53270-130-000 Employee Benefits	0.00	0.00	0.00	0.00	0.00	0.00	2,810.41	2,810.41	-2,810.41	0.00
26-701-29-53270-220-000 Utilities	0.00	0.00	0.00	0.00	0.00	0.00	20,584.98	20,584.98	-20,584.98	0.00
26-701-29-53270-240-000 Contracted Maintenance	0.00	0.00	0.00	0.00	0.00	0.00	3,719.35	3,719.35	-3,719.35	0.00
26-701-29-53270-350-000 Repair & Maintenance	0.00	0.00	0.00	0.00	0.00	0.00	1,262.57	1,262.57	-1,262.57	0.00
26-701-29-53270-534-000 Machinery Rental	0.00	0.00	0.00	0.00	0.00	0.00	2,162.24	2,162.24	-2,162.24	0.00
<b>53270 Buildings &amp; Ground Operations Cost Pool</b>	<b>\$0.00</b>	<b>\$0.00</b>	<b>\$0.00</b>	<b>\$0.00</b>	<b>\$0.00</b>	<b>\$0.00</b>	<b>\$35,201.06</b>	<b>\$35,201.06</b>	<b>-\$35,201.06</b>	<b>0.00</b>
<b>53271 Salt Sheds Cost Pool</b>										
26-701-29-53271-120-000 Wages	0.00	0.00	0.00	0.00	0.00	0.00	368.83	368.83	-368.83	0.00
26-701-29-53271-130-000 Employee Benefits	0.00	0.00	0.00	0.00	0.00	0.00	222.37	222.37	-222.37	0.00
26-701-29-53271-350-000 Repair & Maintenance	0.00	0.00	0.00	0.00	0.00	0.00	26.31	26.31	-26.31	0.00
26-701-29-53271-534-000 Machinery Rental	0.00	0.00	0.00	0.00	0.00	0.00	406.07	406.07	-406.07	0.00
<b>53271 Salt Sheds Cost Pool</b>	<b>\$0.00</b>	<b>\$0.00</b>	<b>\$0.00</b>	<b>\$0.00</b>	<b>\$0.00</b>	<b>\$0.00</b>	<b>\$1,023.58</b>	<b>\$1,023.58</b>	<b>-\$1,023.58</b>	<b>0.00</b>
<b>53281 Capital Equipment</b>										
26-701-29-53281-810-000 Capital Equipment	940,790.00	0.00	940,790.00	0.00	0.00	0.00	444,484.36	444,484.36	496,305.64	52.75
<b>53281 Capital Equipment</b>	<b>\$940,790.00</b>	<b>\$0.00</b>	<b>\$940,790.00</b>	<b>\$0.00</b>	<b>\$0.00</b>	<b>\$0.00</b>	<b>\$444,484.36</b>	<b>\$444,484.36</b>	<b>\$496,305.64</b>	<b>52.75</b>
<b>53309 County Supervision</b>										
26-701-29-53309-110-000 Salaries	88,609.00	0.00	88,609.00	0.00	0.00	0.00	25,109.60	25,109.60	63,499.40	71.66
26-701-29-53309-120-000 Wages	250.00	0.00	250.00	0.00	0.00	0.00	44.61	44.61	205.39	82.16
26-701-29-53309-130-000 Employee Benefits	47,611.00	0.00	47,611.00	0.00	0.00	0.00	15,462.71	15,462.71	32,148.29	67.52
26-701-29-53309-225-000 Telephone	2,300.00	0.00	2,300.00	0.00	0.00	0.00	1,158.00	1,158.00	1,142.00	49.65
26-701-29-53309-310-000 Office Supplies	1,948.00	0.00	1,948.00	0.00	0.00	0.00	1,758.79	1,758.79	189.21	9.71
26-701-29-53309-350-000 Repair & Maintenance	6,600.00	0.00	6,600.00	0.00	0.00	0.00	2,178.64	2,178.64	4,421.36	66.99
26-701-29-53309-534-000	17,591.00	0.00	17,591.00	0.00	0.00	0.00	4,876.60	4,876.60	12,714.40	72.28

**Expenditure Summary**

**Finance Committee-Sum-Expenditure**

GREEN LAKE COUNTY

Report Description: 100 Account Year: 26 Account Period Range: 01 - 04 Date Range: 01/01/2026 - 04/30/2026

Account	Original Budget	Adjustments	Adjusted Budget	Encumbrances Current	YTD	Expenditures Current	YTD	Available	Percent
<b>Account Description</b>									
<b>26 CALENDAR YEAR 2026</b>									
<b>701 Highway</b>									
<b>53309 County Supervision</b>									
Machinery Rentals									
<b>53309 County Supervision</b>	<b>\$164,909.00</b>	<b>\$0.00</b>	<b>\$164,909.00</b>	<b>\$0.00</b>	<b>\$0.00</b>	<b>\$50,588.95</b>	<b>\$50,588.95</b>	<b>\$114,320.05</b>	<b>69.32</b>
<b>53310 General Mtn. C.T.H's</b>									
26-701-29-53310-101-120	195,661.00	0.00	195,661.00	0.00	0.00	90,752.19	90,752.19	104,908.81	53.62
Wages									
26-701-29-53310-101-125	1,024.00	0.00	1,024.00	0.00	0.00	214.42	214.42	809.58	79.06
Overtime									
26-701-29-53310-101-130	105,384.00	0.00	105,384.00	0.00	0.00	54,843.76	54,843.76	50,540.24	47.96
Benefits									
26-701-29-53310-101-350	4,780.00	0.00	4,780.00	0.00	0.00	6,224.01	6,224.01	-1,444.01	0.00
Repair & Maintenance									
26-701-29-53310-101-362	13,502.00	0.00	13,502.00	0.00	0.00	2,041.32	2,041.32	11,460.68	84.88
Consumable Small Tool									
26-701-29-53310-101-370	90,489.00	0.00	90,489.00	0.00	0.00	3,946.00	3,946.00	86,543.00	95.64
Road Supplies									
26-701-29-53310-101-534	239,178.00	0.00	239,178.00	0.00	0.00	92,934.60	92,934.60	146,243.40	61.14
Equipment/Machinery									
26-701-29-53310-102-120	24,348.00	0.00	24,348.00	0.00	0.00	10,790.66	10,790.66	13,557.34	55.68
Wages									
26-701-29-53310-102-125	300.00	0.00	300.00	0.00	0.00	0.00	0.00	300.00	100.00
Overtime									
26-701-29-53310-102-130	13,206.00	0.00	13,206.00	0.00	0.00	6,505.69	6,505.69	6,700.31	50.74
Benefits									
26-701-29-53310-102-350	744.00	0.00	744.00	0.00	0.00	2,498.20	2,498.20	-1,754.20	0.00
Repair & Maintenance									
26-701-29-53310-102-362	1,779.00	0.00	1,779.00	0.00	0.00	242.14	242.14	1,536.86	86.39
Consumable Small Tool									
26-701-29-53310-102-370	109,244.00	0.00	109,244.00	0.00	0.00	2,578.74	2,578.74	106,665.26	97.64
Road Supplies									
26-701-29-53310-102-534	15,448.00	0.00	15,448.00	0.00	0.00	10,746.94	10,746.94	4,701.06	30.43
Equipment/Machinery									
26-701-29-53310-103-120	4,782.00	0.00	4,782.00	0.00	0.00	0.00	0.00	4,782.00	100.00
Wages									
26-701-29-53310-103-130	2,562.00	0.00	2,562.00	0.00	0.00	0.00	0.00	2,562.00	100.00
Benefits									
26-701-29-53310-103-362	345.00	0.00	345.00	0.00	0.00	0.00	0.00	345.00	100.00
Consumable Small Tool									
26-701-29-53310-103-370	11,582.00	0.00	11,582.00	0.00	0.00	0.00	0.00	11,582.00	100.00
Road Supplies									
26-701-29-53310-103-534	9,480.00	0.00	9,480.00	0.00	0.00	0.00	0.00	9,480.00	100.00
Equipment/Machinery									
26-701-29-53310-104-120	43,518.00	0.00	43,518.00	0.00	0.00	648.63	648.63	42,869.37	98.51

**Expenditure Summary**

**Finance Committee-Sum-Expenditure**

GREEN LAKE COUNTY

Report Description: 100 Account Year: 26 Account Period Range: 01 - 04 Date Range: 01/01/2026 - 04/30/2026

Account	Original Budget	Adjustments	Adjusted Budget	Encumbrances Current	YTD	Expenditures Current	YTD	Available	Percent
<b>Account Description</b>									
<b>26 CALENDAR YEAR 2026</b>									
<b>701 Highway</b>									
<b>53310 General Mtn. C.T.H's</b>									
Wages									
26-701-29-53310-104-125 OT	234.00	0.00	234.00	0.00		0.00	0.00	234.00	100.00
26-701-29-53310-104-130 Benefits	23,442.00	0.00	23,442.00	0.00		391.06	391.06	23,050.94	98.33
26-701-29-53310-104-362 Consumable Small Tool	3,158.00	0.00	3,158.00	0.00		14.56	14.56	3,143.44	99.54
26-701-29-53310-104-370 Road Supplies	49,369.00	0.00	49,369.00	0.00		0.00	0.00	49,369.00	100.00
26-701-29-53310-104-534 Equipment/Machinery	36,429.00	0.00	36,429.00	0.00		1,305.06	1,305.06	35,123.94	96.42
<b>53310 General Mtn. C.T.H's</b>	<b>\$999,988.00</b>	<b>\$0.00</b>	<b>\$999,988.00</b>	<b>\$0.00</b>	<b>\$0.00</b>	<b>\$286,677.98</b>	<b>\$286,677.98</b>	<b>\$713,310.02</b>	<b>71.33</b>
<b>53311 C.T.H's Winter Mtn.</b>									
26-701-29-53311-120-000 Wages	91,688.00	0.00	91,688.00	0.00		56,723.45	56,723.45	34,964.55	38.13
26-701-29-53311-125-000 Overtime	28,509.00	0.00	28,509.00	0.00		16,888.43	16,888.43	11,620.57	40.76
26-701-29-53311-130-000 Employee Benefits	64,402.00	0.00	64,402.00	0.00		44,380.64	44,380.64	20,021.36	31.09
26-701-29-53311-350-000 Repair & Maintenance	4,235.00	0.00	4,235.00	0.00		746.46	746.46	3,488.54	82.37
26-701-29-53311-362-000 Consumable Small Tools	8,676.00	0.00	8,676.00	0.00		1,651.90	1,651.90	7,024.10	80.96
26-701-29-53311-370-000 Road supplies	152,427.00	0.00	152,427.00	0.00		90,698.11	90,698.11	61,728.89	40.50
26-701-29-53311-534-000 Machinery Rental	239,292.00	0.00	239,292.00	0.00		182,948.06	182,948.06	56,343.94	23.55
<b>53311 C.T.H's Winter Mtn.</b>	<b>\$589,229.00</b>	<b>\$0.00</b>	<b>\$589,229.00</b>	<b>\$0.00</b>	<b>\$0.00</b>	<b>\$394,037.05</b>	<b>\$394,037.05</b>	<b>\$195,191.95</b>	<b>33.13</b>
<b>53312 C.T.H's Bridge Mtn &amp; Insp CTH's</b>									
26-701-29-53312-000-000 Bridge Maintenance and Inspection - CTH's	7,600.00	0.00	7,600.00	0.00		12,891.11	12,891.11	-5,291.11	0.00
<b>53312 C.T.H's Bridge Mtn &amp; Insp CTH's</b>	<b>\$7,600.00</b>	<b>\$0.00</b>	<b>\$7,600.00</b>	<b>\$0.00</b>	<b>\$0.00</b>	<b>\$12,891.11</b>	<b>\$12,891.11</b>	<b>-\$5,291.11</b>	<b>0.00</b>
<b>53313 Reconstruction</b>									
26-701-29-53313-000-000 Reconstruction-CTH's	2,824,098.00	0.00	2,824,098.00	0.00		182,874.52	182,874.52	2,641,223.48	93.52
<b>53313 Reconstruction</b>	<b>\$2,824,098.00</b>	<b>\$0.00</b>	<b>\$2,824,098.00</b>	<b>\$0.00</b>	<b>\$0.00</b>	<b>\$182,874.52</b>	<b>\$182,874.52</b>	<b>\$2,641,223.48</b>	<b>93.52</b>
<b>53315 Chip Seal Coat</b>									
26-701-29-53315-000-000 Chip Seal Coat	286,409.00	0.00	286,409.00	0.00		0.00	0.00	286,409.00	100.00

**Expenditure Summary**

**Finance Committee-Sum-Expenditure**

GREEN LAKE COUNTY

Report Description: 100 Account Year: 26 Account Period Range: 01 - 04 Date Range: 01/01/2026 - 04/30/2026

Account	Original Budget	Adjustments	Adjusted Budget	Encumbrances Current	YTD	Expenditures Current	YTD	Available	Percent
<b>Account Description</b>									
<b>26 CALENDAR YEAR 2026</b>									
<b>701 Highway</b>									
<b>53315 Chip Seal Coat</b>									
53315 Chip Seal Coat	\$286,409.00	\$0.00	\$286,409.00	\$0.00	\$0.00	\$0.00	\$0.00	\$286,409.00	100.00
<b>53321 Routine Maintenance</b>									
26-701-29-53321-000-000 Routine Maintenance - State	0.00	0.00	0.00	0.00	0.00	497.56	497.56	-497.56	0.00
26-701-29-53321-120-000 Wages	93,464.00	0.00	93,464.00	0.00	0.00	36,112.23	36,112.23	57,351.77	61.36
26-701-29-53321-125-000 Overtime	10,418.00	0.00	10,418.00	0.00	0.00	5,254.23	5,254.23	5,163.77	49.57
26-701-29-53321-130-000 Employee Benefits	55,661.00	0.00	55,661.00	0.00	0.00	24,939.84	24,939.84	30,721.16	55.19
26-701-29-53321-350-000 Repair & Maintenance	17,395.00	0.00	17,395.00	0.00	0.00	1,042.06	1,042.06	16,352.94	94.01
26-701-29-53321-362-000 Consumable Small Tools	7,499.00	0.00	7,499.00	0.00	0.00	928.27	928.27	6,570.73	87.62
26-701-29-53321-370-000 Road Supplies	83,532.00	0.00	83,532.00	0.00	0.00	9,440.65	9,440.65	74,091.35	88.70
26-701-29-53321-534-000 Machinery Repair	144,782.00	0.00	144,782.00	0.00	0.00	79,619.44	79,619.44	65,162.56	45.01
<b>53321 Routine Maintenance</b>	<b>\$412,751.00</b>	<b>\$0.00</b>	<b>\$412,751.00</b>	<b>\$0.00</b>	<b>\$0.00</b>	<b>\$157,834.28</b>	<b>\$157,834.28</b>	<b>\$254,916.72</b>	<b>61.76</b>
<b>53333 Cities, Towns, Villages</b>									
26-701-29-53333-120-000 Wages	54,619.00	0.00	54,619.00	0.00	0.00	10,669.78	10,669.78	43,949.22	80.47
26-701-29-53333-125-000 Overtime	8,309.00	0.00	8,309.00	0.00	0.00	4,623.07	4,623.07	3,685.93	44.36
26-701-29-53333-130-000 Employee Benefits	33,717.00	0.00	33,717.00	0.00	0.00	9,220.07	9,220.07	24,496.93	72.65
26-701-29-53333-350-000 Repair & Maintenance	30,050.00	0.00	30,050.00	0.00	0.00	9,531.14	9,531.14	20,518.86	68.28
26-701-29-53333-362-000 Consumable Small Tools	4,542.00	0.00	4,542.00	0.00	0.00	343.17	343.17	4,198.83	92.44
26-701-29-53333-370-000 Road Supplies	279,536.00	0.00	279,536.00	0.00	0.00	58,079.75	58,079.75	221,456.25	79.22
26-701-29-53333-534-000 Machinery Rental	159,475.00	0.00	159,475.00	0.00	0.00	59,209.21	59,209.21	100,265.79	62.87
<b>53333 Cities, Towns, Villages</b>	<b>\$570,248.00</b>	<b>\$0.00</b>	<b>\$570,248.00</b>	<b>\$0.00</b>	<b>\$0.00</b>	<b>\$151,676.19</b>	<b>\$151,676.19</b>	<b>\$418,571.81</b>	<b>73.40</b>
<b>53334 Interdepartment Charges</b>									
26-701-29-53334-000-000 Interdepartmental Charges	131,488.00	0.00	131,488.00	0.00	0.00	10,828.17	10,828.17	120,659.83	91.76
<b>53334 Interdepartment Charges</b>	<b>\$131,488.00</b>	<b>\$0.00</b>	<b>\$131,488.00</b>	<b>\$0.00</b>	<b>\$0.00</b>	<b>\$10,828.17</b>	<b>\$10,828.17</b>	<b>\$120,659.83</b>	<b>91.76</b>
<b>29 Highway</b>	<b>\$6,778,226.00</b>	<b>\$0.00</b>	<b>\$6,778,226.00</b>	<b>\$0.00</b>	<b>\$0.00</b>	<b>\$1,495,065.85</b>	<b>\$1,495,065.85</b>	<b>\$5,283,160.15</b>	<b>77.94</b>
<b>701 Highway</b>	<b>\$6,778,226.00</b>	<b>\$0.00</b>	<b>\$6,778,226.00</b>	<b>\$0.00</b>	<b>\$0.00</b>	<b>\$1,495,065.85</b>	<b>\$1,495,065.85</b>	<b>\$5,283,160.15</b>	<b>77.94</b>



# GREEN LAKE COUNTY HIGHWAY COMMISSION

Derek Mashuda  
Highway Commissioner

Office: 920-294-4060  
Fax: 920-294-4066  
Email: [dmashuda@greenlakecountywi.gov](mailto:dmashuda@greenlakecountywi.gov)

---

## Commissioner's Report June 10<sup>th</sup>, 2026

### Previous month review

- Patching
- CTH GG Ditch Work
- State DMA Crack Filling (HWY 23/73)
- County Crack Filling
- Chip Seal
- Township Work
- PGR Spraying

### Upcoming activities

- State DMA Crack Filling (HWY 23/73)
- Punchlist on CTH H and CTH GG
- Township work
- Patching
- Start CTH N Project

240830 Green Lake - Monumental Sign Pricing for Larger Versions			5/27/2027		
Contractor		Sign Costs			Notes
	9'-0" Sign on Current Drawings	14'-0" Sign	19-8" Sign		
Mashuda (Excavation)	\$ 3,600.00	\$ 1,350.00	\$ 2,700.00		
Miron Concrete	In Bid	\$ 3,097.00	\$ 6,164.00		
Wells Precast	\$ 8,885.00	\$ 9,550.00	\$ 10,370.00		
Miron Masonry	In Bid	\$ 11,100.00	\$ 18,000.00		
Eagle Sign	In Bid	\$ 4,160.00	\$ 6,580.00		
Total for Current Sign per BP#2 Drawings	\$ 12,485.00				Sign Drawing A1.7 was not part of the BP#1 drawings Mashuda and Wells did not include the sign work so this will be a PCI for the current design on A1.7
Cost above and beyond what is currently details on A1.7		\$ 29,257.00	\$ 43,814.00		
Total Added Cost for 14'-0" sign		\$ 41,742.00	\$ 56,299.00		PCI total for larger signs

**PROJECT INFORMATION**

NEW HIGHWAY FACILITY:  
**GREEN LAKE COUNTY HIGHWAY COMMISSION**  
 N4843 WI-73 • PRINCETON, WI 54968

PROFESSIONAL SEAL

<b>SHEET DATES</b>	
ISSUED FOR CONSTRUCTION	
CB1	OCT. 29, 2025

**JOB NUMBER**  
230486600

**SHEET NUMBER**  
**A1.7**

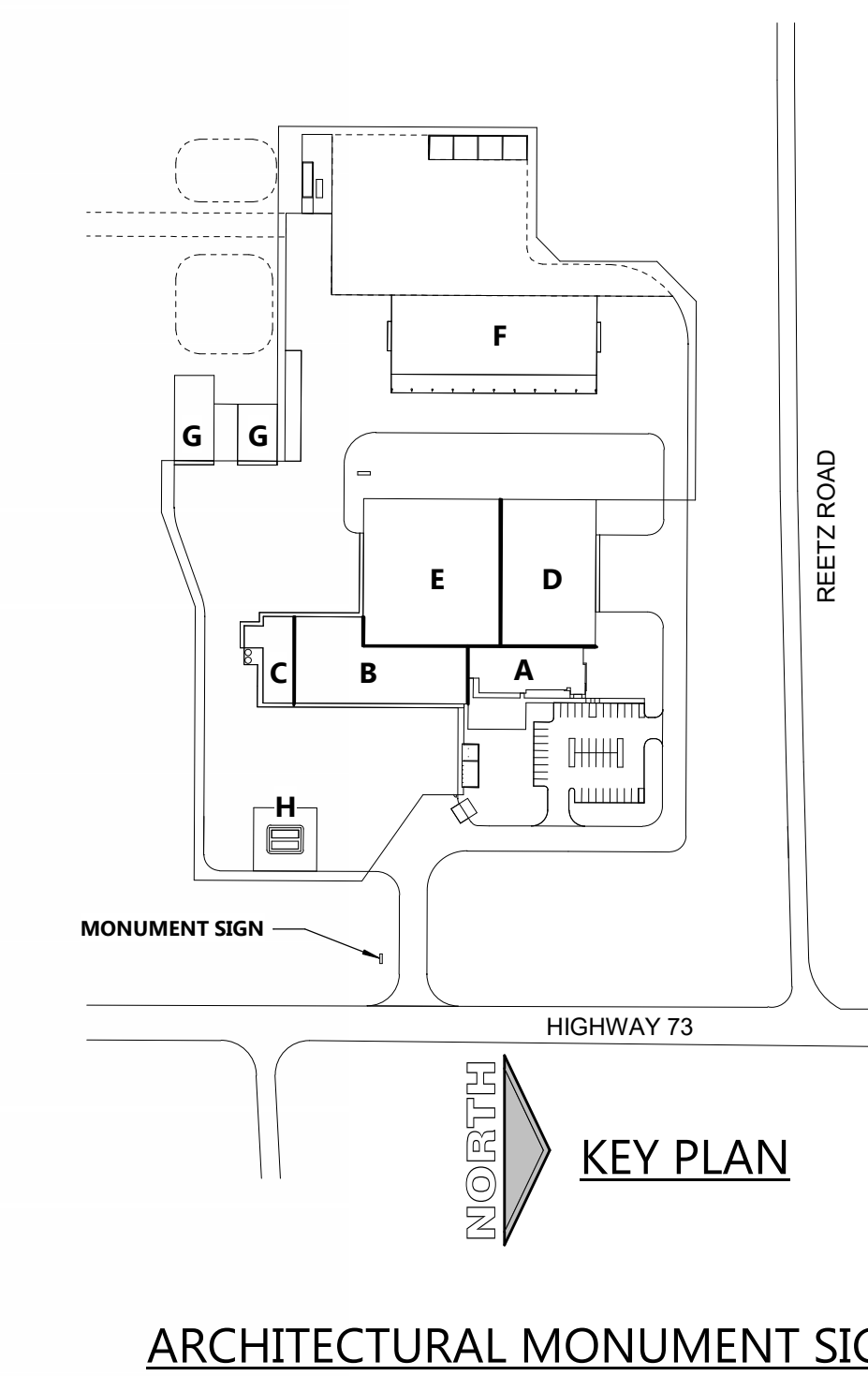
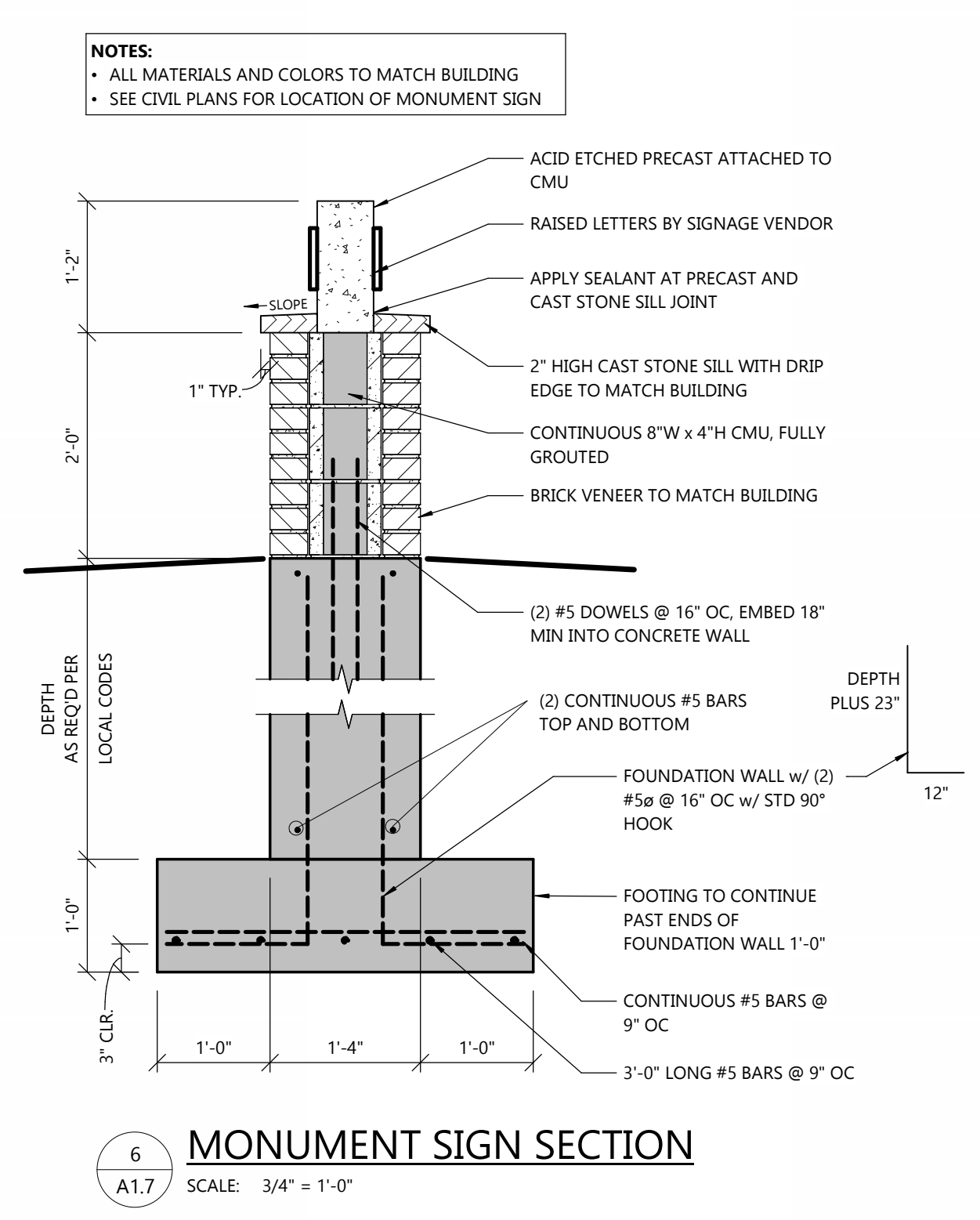
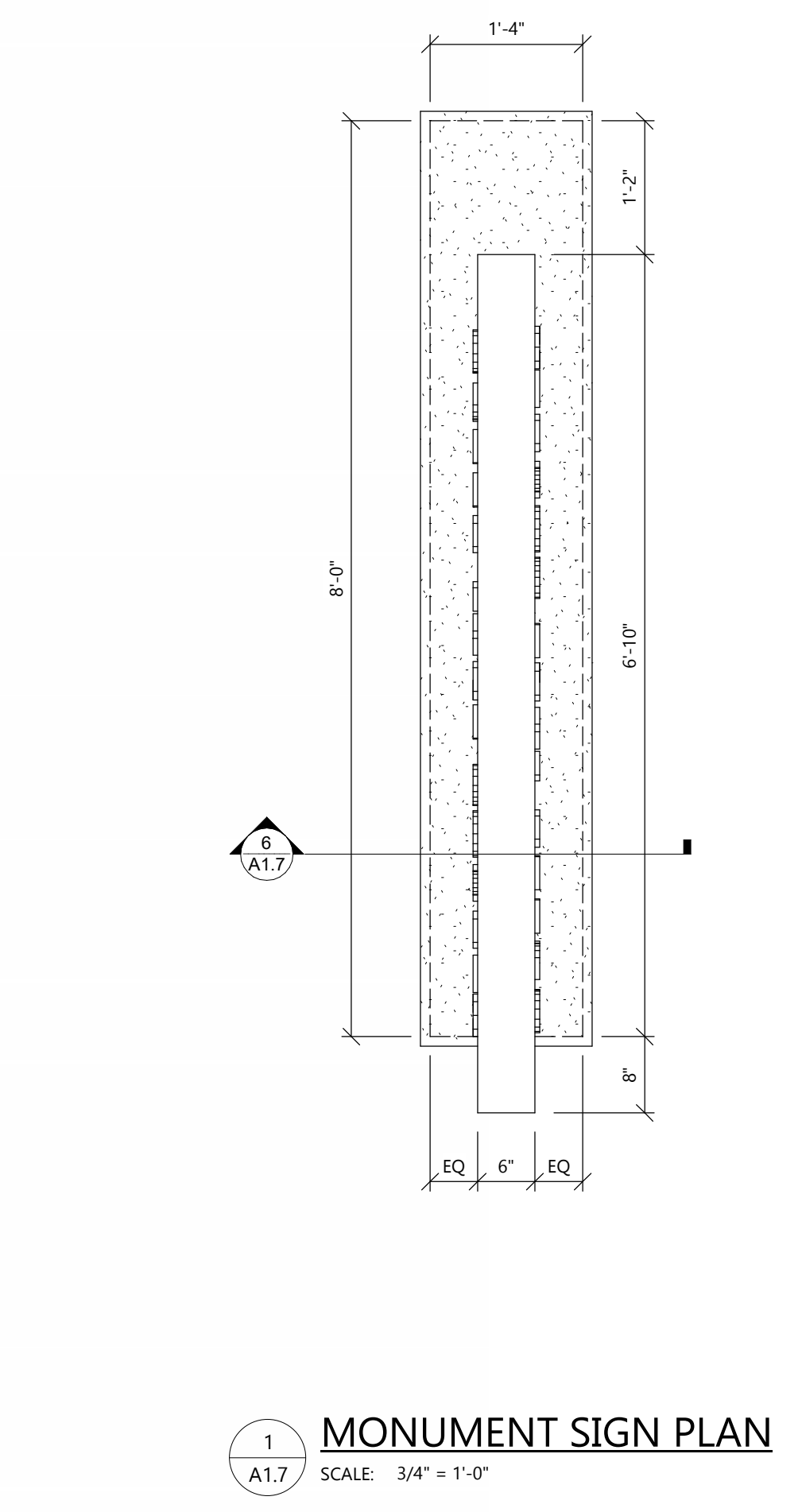
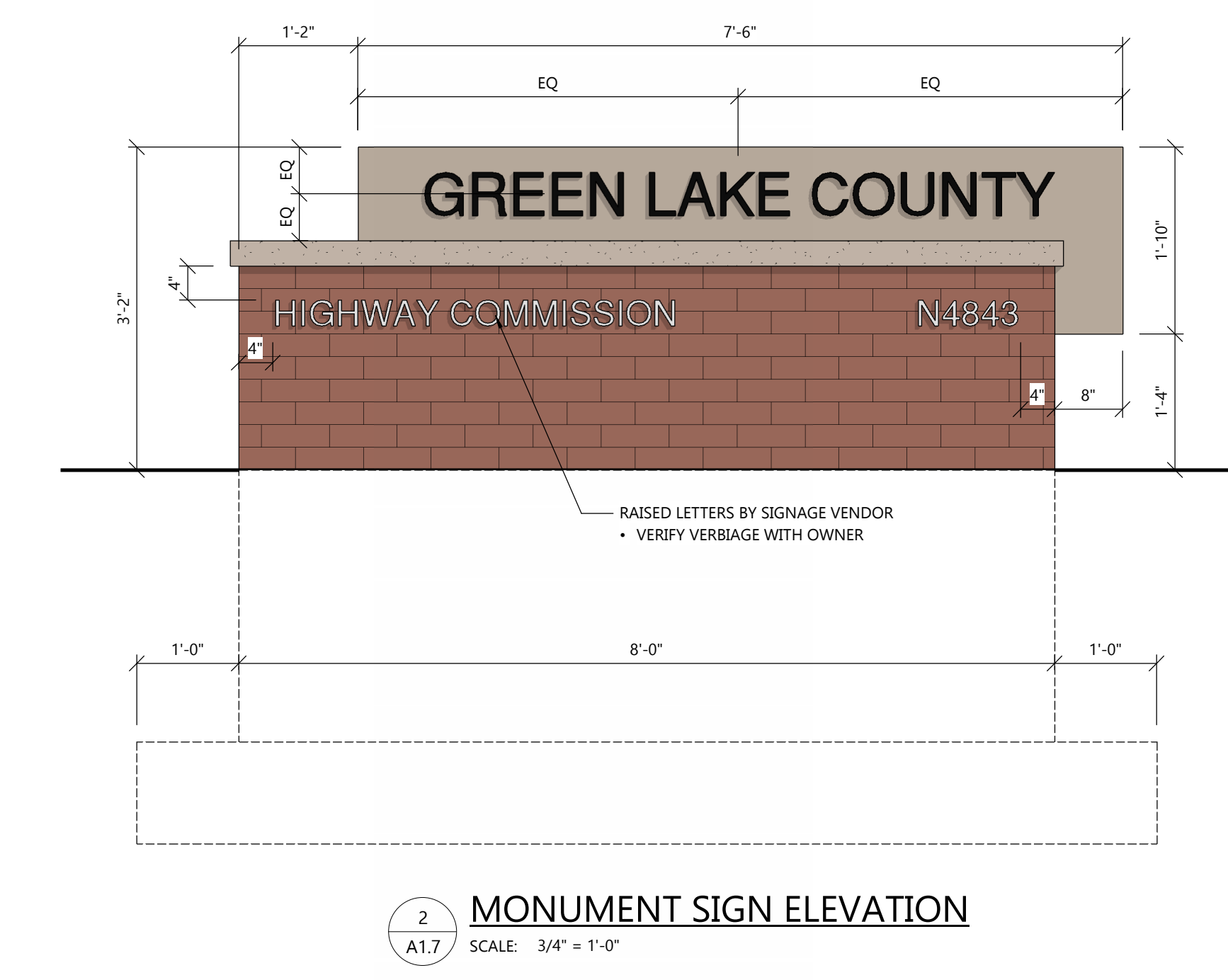
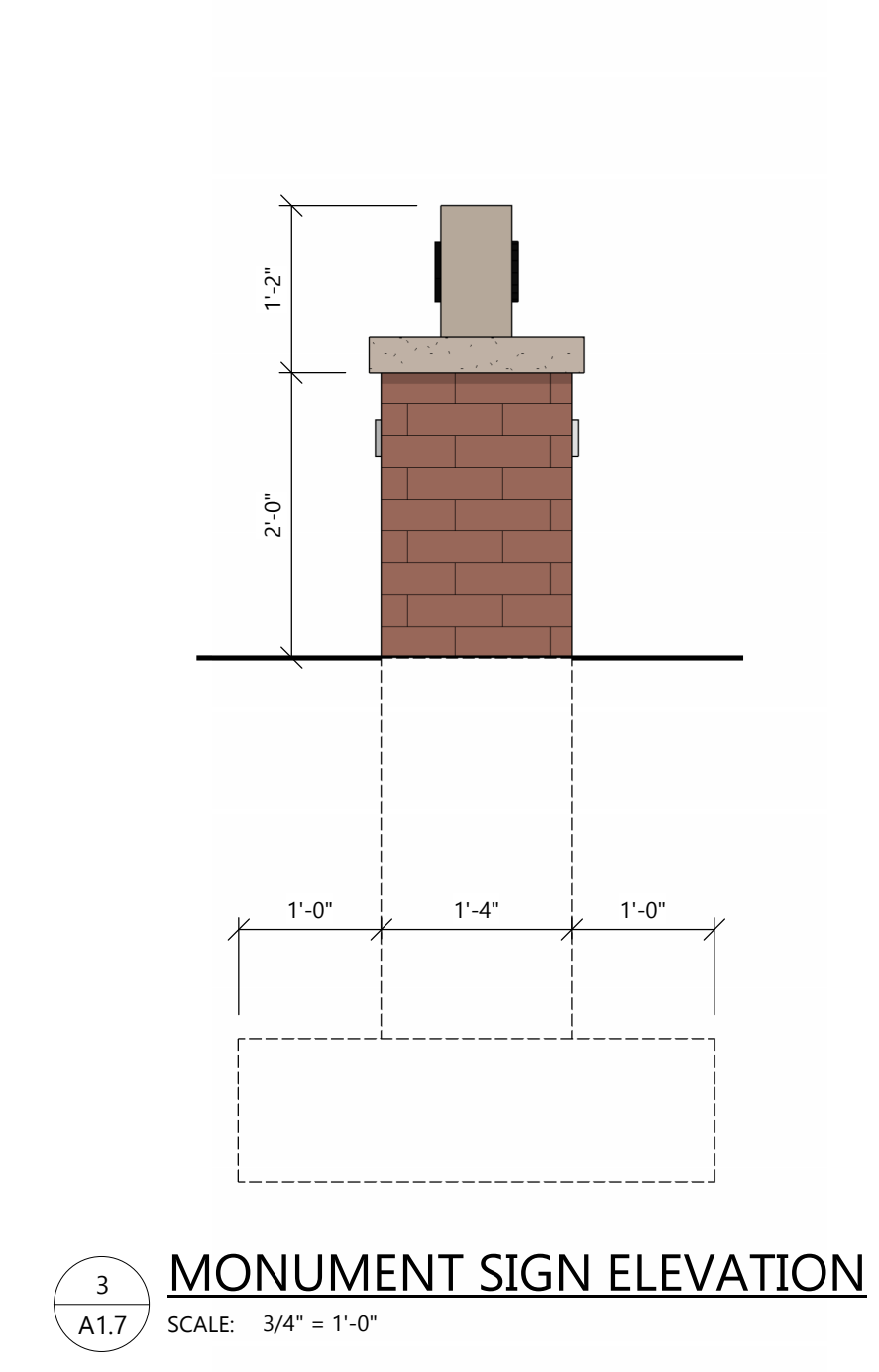
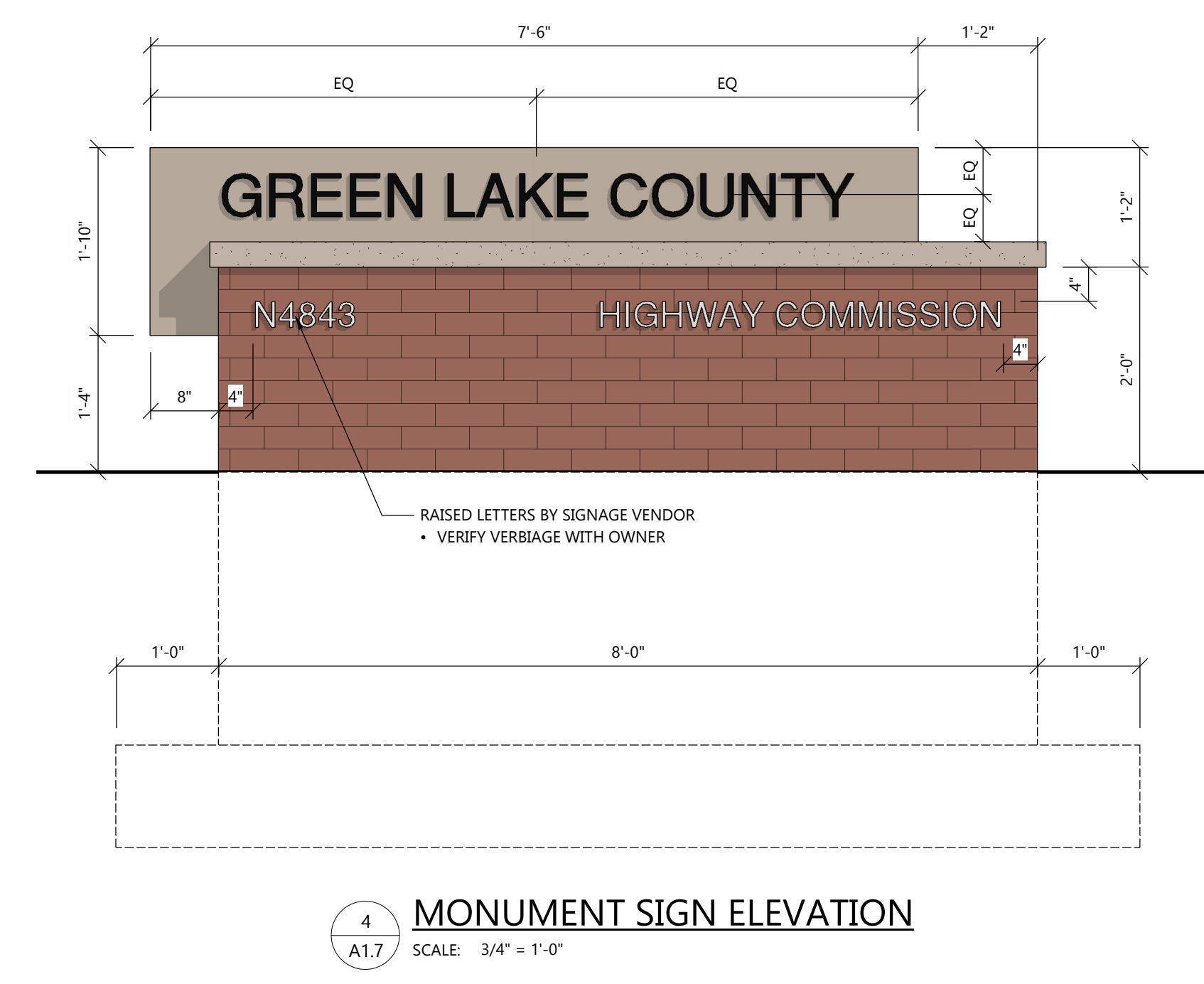
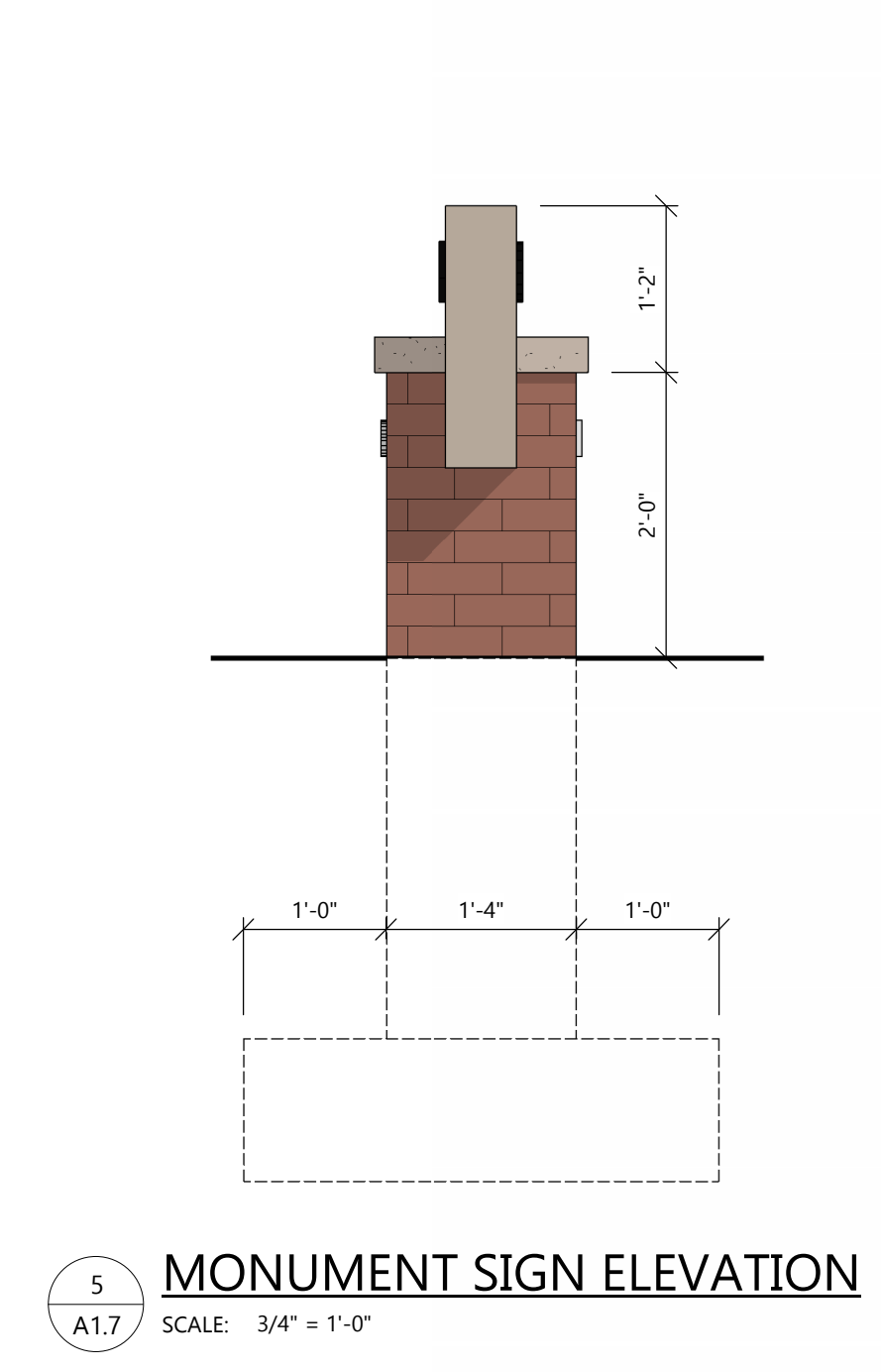

Excel has received a PDF of the existing signage at the Green Lake Justice Center. After further discussion with Derek, he believes the board might want to increase the size of the monument sign to more closely match what is shown at the Justice Center. Derek also noted that the board would likely want to see a cost comparison between the three different monument size.

GC to provide and estimate on the cost for the three different monument size options.

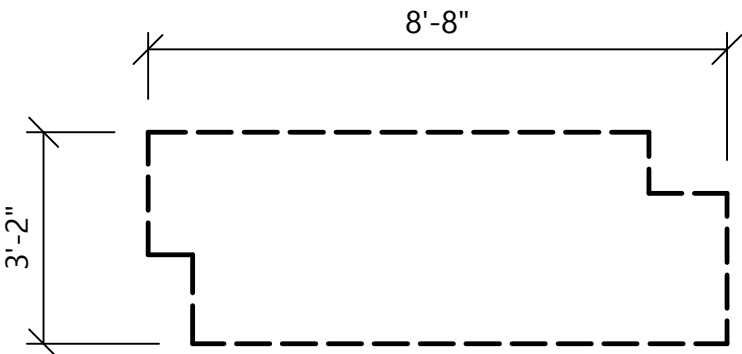

Current GLC Monument Sign Size

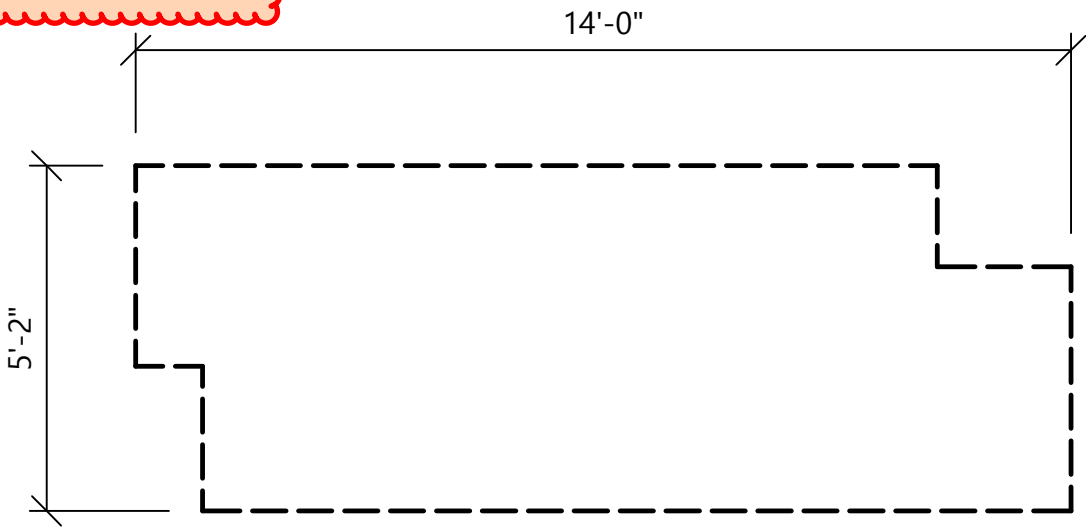

Increased GLC Monument Sign Size  
(x1.625 the size of the current GLC sign)

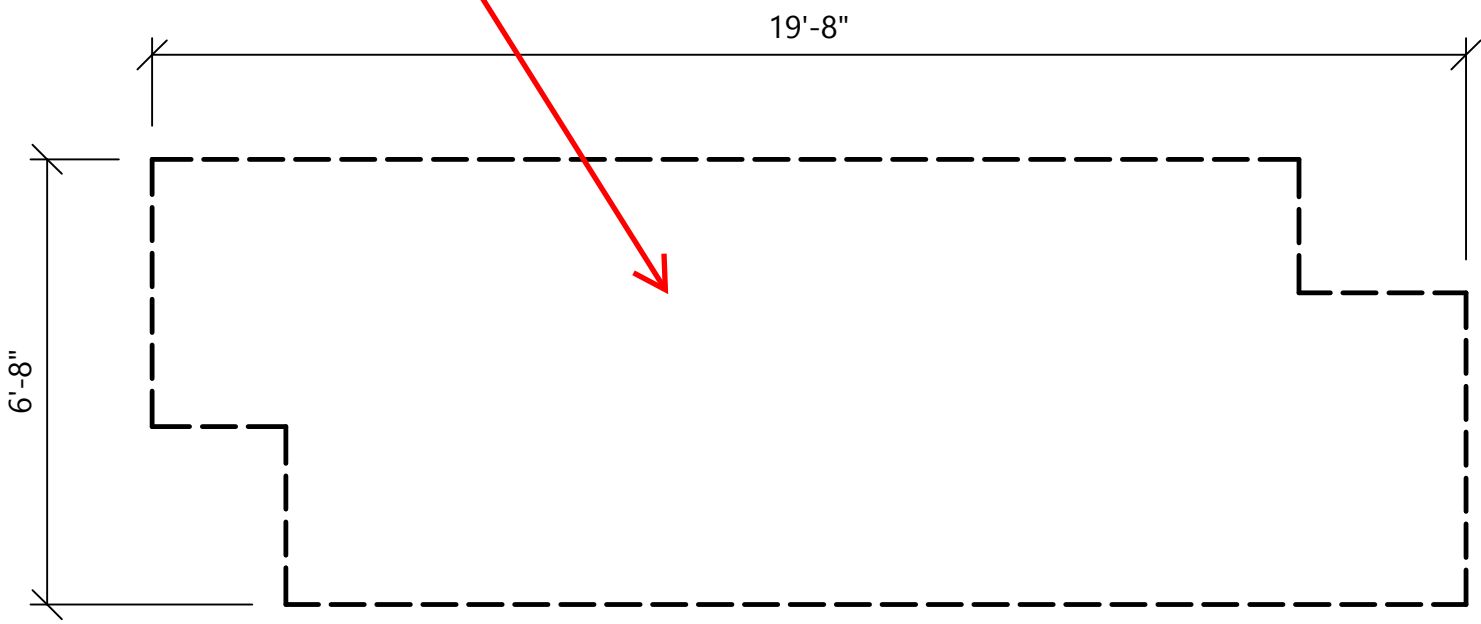

Current Justice Center Monument Sign Size  
(x2.25 the size of the current GLC sign)

# Existing signage at government building (for reference only)



**Plan View**  
scale: 1/4" = 1'-0"



**Side B Elevation**  
scale: 1/8" = 1'-0"

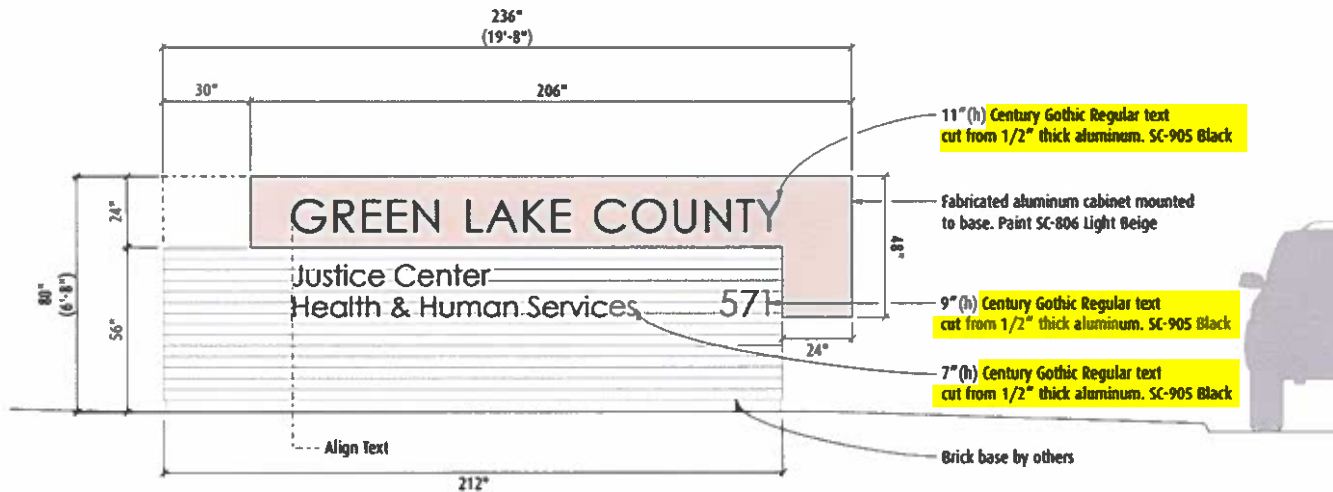

**Side A Elevation**  
scale: 1/4" = 1'-0"



**Specifications:**

**ASI Series:** L400  
**Mounting:** Mechanical attachment to base by others

**DESIGN STATUS:**

<input type="checkbox"/>	Approved
<input type="checkbox"/>	Approved as noted
<input type="checkbox"/>	Devise and resubmit

DATE: \_\_\_\_\_  
SIGN: \_\_\_\_\_

Client:	Green Lake County
Project:	Justice Center
Contact:	SK
Scale:	Noted
Drawn By:	BLJ
Date:	06.30.09
File Name:	GreenLakeJF_#10
Revised:	11.12.09, 02.02.10

## Ground Sign A

These drawings involve confidential proprietary rights of ASI-Signage and all design, manufacturing, reproduction, use and sale rights regarding the same are expressly reserved. These drawings are submitted under a confidential relationship for a specified purpose and the recipient, by accepting this document, assumes custody and agrees (a) that this document will not be copied or reproduced in whole or in part, nor its contents revealed in any manner or to any person except to meet the purpose for which it was delivered and (b) that any special features peculiar to this design will not be incorporated into other projects.



# Change Order Request

**Date:** 05/18/2026  
**To:** Derek Mashuda  
Green Lake County  
571 County Rd A  
Green Lake, WI 54941

**Re:** Green Lake County Highway Facility  
Princeton, WI 54968  
**Project:** 240830

**Reference Document:** PCI0020

**Change Description:** Per CB#1 Raising the Cold Storage Area F Top of Foundation by 4'-0" to create a bump wall, scope changes include the forming system due to an 8'-0" wall height in lieu of 4'-0", added reinforcing, concrete, equipment for placing material, labor for reinforcing, and concrete and labor to fill the tie holes and rub all exposed exterior concrete walls for a smooth finish. **NOTE: This allowance expense was not submitted before now to ensure any changes to the PEMB foundations were captured. There were no changes with Excel's review.**

Contractor	Description	Amount
Miron Construction Co., Inc.	CONCRETE WORK	\$203,630.57
	BID PACKAGE #1 SCOPE ALLOWANCE	-\$203,630.57
<b>** TOTAL **</b>		<b>0.00</b>

Impacted Calendar Days: 0

All terms of our agreement apply and preclude Miron Construction Co., Inc. from performing any extra work without approval. Please provide your approval by signing this request.

DocuSigned by:

*Brian Frye*  
21B3F192BD5646C...

5/27/2026

**Brian Frye**  
Miron Construction Co., Inc.

**Date:**

**Owner Representative**  
Green Lake County

**Date:**

This quote expires on: 06/16/2026

Signed by:

*David Vanden Brond*  
A29FDC798CB943E...

5/28/2026

**Engineer Representative**  
Excel Engineering Inc

**Date:**



## Miron Self-Perform Concrete Quote Detail

**Date:** 05/01/2026  
**To:** Miron Construction Co., Inc.  
 PO Box 509  
 Neenah, WI 54956  
**Re:** Green Lake County Highway Facility-Concrete  
 Princeton, WI 54968  
**Project:** 240833

**Reference Document:** PCI0006

**Change Description:** CB01 Area F Foundation Changes

Contractor	Description	Amount
Miron Construction Co., Inc	Labor	118,041.69
Miron Construction Co., Inc	Material	28,675.39
Nucor Rebar Fabrication Midwest LLC	Reinforcing Steel Supply	22,515.00
Reger Companies Inc	Install Reinforcing Steel ( 7.02TN @ \$1,200/TN)	8,424.00
<b>* SUB-TOTAL *</b>		<b>177,656.08</b>
Management Fee - Subcontractor		589.68
Management Fee - Self Perform		22,007.56
Management Fee - Supplier		3,377.25
<b>** TOTAL **</b>		<b>203,630.57</b>

Impacted Calendar Days: 0

All terms of our agreement apply and preclude Miron Construction Co., Inc. from performing any extra work without approval. Please provide your approval by signing this request.

Hunter Havrilla  
 Hunter Havrilla  
 Miron Construction Co., Inc.

05/01/2026  
 Date:

**Project Modification  
Pricing Worksheet**

**Project No.:** 240833  
**Project Name:** Green Lake County Hwy Facility - Concrete  
**Desc of C/O:**  
**Scope Description:** CB01  
**Prepared by:** Hunter Havrilla  
**Date:** 5.1.2026

**Labor Rate:** Project Specific  
**Equip Rate:** Equip



Excludes: Testing

Schedule Impact: 6 Weeks

ID	Division	Cost Code	Item Description	Cost Type	Quantity	Unit of Measure	Labor Rate				Labor		Materials		Equipment				Total	
							Units Per Hour	Hours Per Unit	Hour Type	Total Hours	Rate Type	Hourly Rate	Total \$	Unit Cost	Total\$	Equipment Type	Billing Usage	Unit Cost		Total\$
1			<b>Added 4' Perimeter Wall Height Area F</b>																	
2			Ready Mix/Pour	L	73.00	CY		1.00	Reg	73.00	CARP	91.98	\$ 6,714.54	\$ 165.99	\$ 12,117.27				\$ -	\$ 18,831.81
3			Form/Strip/Setup	L	5,320.00	SF		7.03	Reg	757.00	CARP	91.98	\$ 69,628.86	\$ 2.00	\$ 10,640.00				\$ -	\$ 80,268.86
4			Added Formsavers Install	L	450.00	EA		6.00	Reg	75.00	CARP	91.98	\$ 6,898.50		\$ -			\$ -	\$ 6,898.50	
5			Rubbing of Exterior Exposed Walls	L	2,660.00	SF		20.00	Reg	133.00	CEMF	93.19	\$ 12,394.27	\$ 0.50	\$ 1,330.00				\$ -	\$ 13,724.27
6			<b>Added PC24 Encasements Area F</b>															\$ -	\$ -	
7			Ready Mix/Pour	L	8.00	CY		2.00	Reg	16.00	CARP	91.98	\$ 1,471.68	\$ 165.99	\$ 1,327.92				\$ -	\$ 2,799.60
8			Form/Strip	L	276.00	SF		4.00	Reg	69.00	CARP	91.98	\$ 6,346.62					\$ -	\$ 6,346.62	
9			EFCO Radius Forming Rental + Shipping (\$500 E.W.)	M	1.00	LS								\$ 3,122.20	\$ 3,122.20			\$ -	\$ 3,122.20	
10			Added Formsavers Install	L	70.00	EA		6.00	Reg	11.67	CARP	91.98	\$ 1,073.10					\$ -	\$ 1,073.10	
11			Rubbing of Exterior Exposed Piers	L	276.00	SF		20.00	Reg	13.80	CARP	91.98	\$ 1,269.32	\$ 0.50	\$ 138.00				\$ -	\$ 1,407.32
12			Crawler Crane - 100 Ton (Operator Time)	L	3.00	WK		40.00	Reg	120.00	OPEG	102.04	\$ 12,244.80					\$ -	\$ 12,244.80	
13			<b>Added Rebar + Formsavers Nucor (2.04TN)</b>	M	1.00	LS								\$ 11,565.00	\$ 11,565.00			\$ -	\$ 11,565.00	
14			<b>Truck Scale Rebar Nucor (4.98TN)</b>	M	1.00	LS								\$ 10,950.00	\$ 10,950.00			\$ -	\$ 10,950.00	
31			<b>Subtotals</b>							1,268.47			\$ -	\$ 118,041.69	\$ 51,190.39			\$ -	\$ -	\$ 169,232.08

Effective June 1, 2025 through May 31, 2026

Total Labor:	\$ 118,041.69
Labor Inflation 0%	\$ -
Total Material:	\$ 51,190.39
Total Purchase Orders:	\$ -
Sales Tax@ 0.00%	\$ -
Total Equipment:	\$ -
<b>Total Miron C/O:</b>	<b>\$ 169,232.08</b>



Nucor Rebar Fabrication Midwest LLC

Change Order No.:  
**CO-0001**

# CHANGE ORDER

<b>Bid Item No.:</b> 01	<b>Job No.:</b> 00725537	<b>Job Description:</b> GREEN CNTY HIGHWAY FACILITY	<b>Original C/O Date:</b> 01/08/26	<b>Revised C/O Date:</b>
----------------------------	-----------------------------	--	---------------------------------------	--------------------------

<b>Sell To:</b> M11475 Miron Construction Co Inc Email to: accountspayable@miron-construc	<b>Customer Job Ref. No.:</b> 240833
---	--------------------------------------

**Change Order Description:**  
Changes per CB1 dated 10/29/25  
+4,073 LBS. (This CO includes material only)

Description	Type	Quantity	Unit Price	Line Amount
Changes per CB1 dated 10/29/25	Add	1 LS	\$11,565.00	\$11,565.00
			<b>Total:</b>	<b>\$11,565.00</b>
				<b>Addition To Contract</b>
				<b>Tax: Green Lake County -Extra</b>

Accepted By: Name: \_\_\_\_\_  
(Please Print)

\_\_\_\_\_  
(Signature)

Date: \_\_\_\_\_

Price is good for steel shipped within 30 days.



**Nucor Rebar Fabrication Midwest LLC**

Change Order No.:  
**CO-0004**

# CHANGE ORDER

<b>Bid Item No.:</b> CO-0004	<b>Job No.:</b> 00725537	<b>Job Description:</b> GREEN CNTY HIGHWAY FACILITY	<b>Original C/O Date:</b> 02/25/26	<b>Revised C/O Date:</b>
---------------------------------	-----------------------------	--	---------------------------------------	--------------------------

<b>Sell To:</b> M11475 Miron Construction Co Inc Email to: accountspayable@miron-construc	<b>Customer Job Ref. No.:</b> 240833
---	--------------------------------------

**Change Order Description:**  
Truck Scale Added  
+9,953 LBS. (This CO includes material only)

Description	Type	Quantity	Unit Price	Line Amount
Truck Scale Added	Add	1 LS	\$10,950.00	\$10,950.00
			<b>Total:</b>	<b>\$10,950.00</b>
				<b>Addition To Contract</b>

Accepted By: Name: \_\_\_\_\_  
(Please Print)

\_\_\_\_\_  
(Signature)

Date: \_\_\_\_\_

Price is good for steel shipped within 30 days.



# Change Order Request

**Date:** 05/14/2026  
**To:** Derek Mashuda  
 Green Lake County  
 571 County Rd A  
 Green Lake, WI 54941

**Re:** Green Lake County Highway Facility  
 Princeton, WI 54968  
**Project:** 240830

**Reference Document:** PCI0019

**Change Description:** Operating and Emergency Vents on Fuel Tanks - Per the State of WI requirements, the (2) relocated fuel tanks must have new operating vents installed. Also, per Walt's recommendation and Owner approval, the emergency vents on the existing fuel tanks will also be replaced.

Contractor	Description	Amount
Walts Petroleum Service Inc	FUELING SYSTEMS	\$4,027.64
	PROJECT CONTINGENCY	-\$4,027.64
<b>** TOTAL **</b>		<b>0.00</b>

Impacted Calendar Days: 0

All terms of our agreement apply and preclude Miron Construction Co., Inc. from performing any extra work without approval. Please provide your approval by signing this request.

DocuSigned by:  
  
 \_\_\_\_\_  
 21B3F192BD5646C...  
**Brian Frye** **Date:** 5/19/2026  
**Miron Construction Co., Inc.**

Signed by:  
  
 \_\_\_\_\_  
 7931FB66FA9D430...  
**Owner Representative** **Date:** 5/26/2026  
**Green Lake County**

This quote expires on: 06/05/2026

Signed by:  
  
 \_\_\_\_\_  
 A29FDC798CB943F...  
**Engineer Representative** **Date:** 5/19/2026  
**Excel Engineering Inc**



GILBARCO SERVICE STATION EQUIPMENT  
SALES • SERVICE • INSTALLATION • REPAIR



New Highway Facility  
Princeton, WI  
Miron Project# 240830

CO 051126-LN

RE: CHANGE ORDER REQUEST – REQUIRED AND RECOMMENDED FUEL TANK UPGRADES

Per the result of the recertification inspection of the two aboveground tanks, there is one required vent upgrade that needs to be made on the tanks and one recommended upgrade that needs to be made to the tanks.

- Both gasoline tanks were identified as having an incorrect operating vent installed. The current vents are 2” pressure/vacuum vents. Since the fill pipe is 3”, the operating vent must also be sized to 3” as it has to equal the in-flow or out-flow size of the largest pipe connected to the tank. The cost to upgrade to the correct 3” pressure/vacuum vent is \$864.23. per tank for a total of **\$1,728.46**. No charge for installation as it will be taken care of during the new site installation. This is required.
- Inspector recommended that all of the existing emergency vents be replaced to prevent water intrusion. Each tank is equipped with one (1) 6” emergency vent and two (2) 8” flanged emergency vents. The cost to replace these three emergency vents per tank is \$1,149.59 for a total of **\$2,299.18** This is a recommendation.

If the County approves the replacement of all existing vents on both tanks the total cost increase would be

**\$4,027.64**

Prepared By:

*LeRoy A. Nordmeyer*

LeRoy A. Nordmeyer  
Walt’s Petroleum Service, Inc.  
[leroy@waltspetro.com](mailto:leroy@waltspetro.com)  
715-370-0130

Accepted By: \_\_\_\_\_ Date: \_\_\_\_\_

SIGN, DATE AND RETURN ONE COPY

## Brian Frye

---

**From:** Mashuda, Derek <dmashuda@greenlakecountywi.gov>  
**Sent:** Tuesday, May 12, 2026 11:21 AM  
**To:** Brian Frye  
**Cc:** Elliot Pieper; Bryon Litton  
**Subject:** [E] RE: CHANGE ORDER 051126-LN RECOMENDED VENT UPGRADES

### CAUTION: External Email

Brian,  
I think we should change them out as well so we have a fully updated system ready for us to use when it is complete. For the little extra cost at the end of the day I think it's worth it. Thanks

**Derek Mashuda**  
**Highway**  
**Commissioner**



Green Lake County  
570 South St.  
Green Lake, WI 54941

920-229-5116

920-294-4062

dmashuda@greenlakecountywi.gov

---

**From:** Brian Frye <Brian.Frye@miron-construction.com>  
**Sent:** Tuesday, May 12, 2026 7:56 AM  
**To:** Mashuda, Derek <dmashuda@greenlakecountywi.gov>  
**Cc:** Elliot Pieper <elliott.pieper@excelengineer.com>; Bryon Litton <bryon.litton@miron-construction.com>  
**Subject:** FW: CHANGE ORDER 051126-LN RECOMENDED VENT UPGRADES

[CAUTION: EXTERNAL SENDER This email originated from outside Green Lake County. Do not click links or open attachments unless you recognize the sender and know the content is safe.]

Derek,

See attached from Leroy from our meeting last Thursday on the fuel tanks. Please let me know as soon as you can if you want to have the existing emergency vents replaced on Green Lake's tanks. This is a recommendation from Walt's to replace these emergency vents, but not a state requirement like item #1- installing the correct operating vents. As soon as you let me know I will write a contingency PCI.

Thank you and have a great day.

**Brian Frye**, WHEA Certified  
*Senior Project Manager*  
brian.frye@miron-construction.com

**Miron Construction Co., Inc.**  
PH 715-841-4011 | M 920-573-1886 | FX 715-845-9119  
500 First Street | Wausau, WI 54403

MIRON-CONSTRUCTION.COM



Miron Construction Co., Inc. is proud to be an Equal Opportunity / Affirmative Action Employer. We welcome and encourage ALL qualified applicants to apply for our open career opportunities. This email and attachment(s) may contain privileged and confidential information and are intended for the addressee(s) only. If you have received this email in error, please notify the sender immediately and delete the message. Any other use, printing, copying, forwarding or retention of this email, is strictly prohibited.

---

**From:** Leroy Nordmeyer <[LeroyN@waltspetro.com](mailto:LeroyN@waltspetro.com)>  
**Sent:** Monday, May 11, 2026 9:40 AM  
**To:** Brian Frye <[Brian.Frye@miron-construction.com](mailto:Brian.Frye@miron-construction.com)>  
**Subject:** [E] CHANGE ORDER 051126-LN RECOMENDED VENT UPGRADES

**CAUTION: External Email**

Brian,

Attached is the change order request addressing the items we discussed last Thursday. These items are the required and the recommended venting upgrades per the tank system recertification report.

Let me know if you need any further information.

LeRoy A. Nordmeyer  
Walt's Petroleum Service, Inc.  
[leroy@waltspetro.com](mailto:leroy@waltspetro.com)  
(715) 370-0130





# Change Order Request

**Date:** 05/27/2026  
**To:** Derek Mashuda  
 Green Lake County  
 571 County Rd A  
 Green Lake, WI 54941

**Re:** Green Lake County Highway Facility  
 Princeton, WI 54968  
**Project:** 240830

**Reference Document:** PCI0022

**Change Description:** Split Cost of Missed Door 400E - Per Modern OH Door, they missed door 400E in their BP#3 proposal. Modern OH Door used the BP#2 drawings and door schedule to bid the Project for BP#3. Modern OH Door would have still been the low bidder even with door 400E included in their proposal. This was presented to the Owner and it was decided a fair resolution is to split the cost of the door 50-50. The attached back-up pricing represents a 50-50 split.

Contractor	Description	Amount
Modern Overhead Door	OVERHEAD DOORS	\$20,530.00
	PROJECT CONTINGENCY	-\$20,530.00
<b>** TOTAL **</b>		<b>0.00</b>

Impacted Calendar Days: 0

All terms of our agreement apply and preclude Miron Construction Co., Inc. from performing any extra work without approval. Please provide your approval by signing this request.

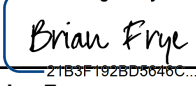
DocuSigned by:  
  
 21B3F192BD5646C...  
 Brian Frye  
 Miron Construction Co., Inc.

5/27/2026  
 Date: \_\_\_\_\_

Owner Representative  
 Green Lake County

Date: \_\_\_\_\_

This quote expires on: 06/17/2026

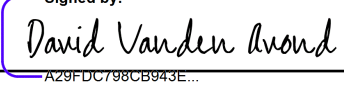
Signed by:  
  
 A29FDC798CB943E...  
 David Vanden Avond  
 Engineer Representative  
 Excel Engineering Inc

5/28/2026  
 Date: \_\_\_\_\_

**Brian Frye**

**From:** Mashuda, Derek <dmashuda@greenlakecountywi.gov>  
**Sent:** Wednesday, May 13, 2026 6:26 AM  
**To:** Brian Frye  
**Cc:** Eric Brandt; Bryon Litton  
**Subject:** RE: [E] RE: 240830 Green Lake - Cost of work at Salt Shed

**CAUTION: External Email**

Brian,

We will be discussing this today at our meeting to decide what the committee wants to do with this. That will have to be their decision.

**Derek Mashuda**  
**Highway**  
**Commissioner**



Green Lake County  
570 South St.  
Green Lake, WI 54941

920-229-5116

920-294-4062

dmashuda@greenlakecountywi.gov

400E History for Modern OH Door Bid

- BP1 Drawings there were 2 salt sheds (small and large) One OH Door in each
- BP#1 CB#1 there was on salt shed and two OH Doors
- BP#2 was originally issued with the CB#1 drawings
- BP#2 Addendum #1(see attached) – CB#2 drawings were issued. On Drawing A1.1G the 3rd door 400E was shown and noted on the Excel narrative as being added on plan drawing A1.1G. On drawing A6.3 door 400E was added to the schedule but there was no note in the Excel narrative for drawing A6.3 (OH Door Schedule) that stated this door was added to the schedule.
- Modern OH Door did not submit a bid for Bid Pack #2
- BP#3 included door 400E in the schedule from the initial issuance but Modern used the BP#2 drawing for submitting their BP#3 Bid.

**50% Cost of Door 400E Total this Change is \$20,530.00 (see next page for detail)**

**From:** Brian Frye <Brian.Frye@miron-construction.com>  
**Sent:** Tuesday, May 12, 2026 4:11 PM  
**To:** Mashuda, Derek <dmashuda@greenlakecountywi.gov>  
**Cc:** Eric Brandt <Eric.Brandt@miron-construction.com>; Bryon Litton <bryon.litton@miron-construction.com>  
**Subject:** FW: [E] RE: 240830 Green Lake - Cost of work at Salt Shed

[CAUTION: EXTERNAL SENDER This email originated from outside Green Lake County. Do not click links or open attachments unless you recognize the sender and know the content is safe.]

Derek,

Is there any update on OH Door 400E and what Green Lake might be willing to do to help out the situation with Modern OH Door?

**Brian Frye**, WHEA Certified  
*Senior Project Manager*  
brian.frye@miron-construction.com

**Miron Construction Co., Inc.**  
PH 715-841-4011 | M 920-573-1886 | FX 715-845-9119  
500 First Street | Wausau, WI 54403  
MIRON-CONSTRUCTION.COM

Miron Construction Co., Inc. is proud to be an Equal Opportunity / Affirmative Action Employer. We welcome and encourage ALL qualified applicants to apply for our open career opportunities. This email and attachment(s) may contain privileged and confidential information and are intended for the addressee(s) only. If you have received this email in error, please notify the sender immediately and delete the message. Any other use, printing, copying, forwarding or retention of this email, is strictly prohibited.

**From:** Brian Frye  
**Sent:** Thursday, April 30, 2026 3:19 PM  
**To:** Mashuda, Derek <[dmashuda@greenlakecountywi.gov](mailto:dmashuda@greenlakecountywi.gov)>  
**Cc:** Eric Brandt <[Eric.Brandt@miron-construction.com](mailto:Eric.Brandt@miron-construction.com)>; Bryon Litton <[bryon.litton@miron-construction.com](mailto:bryon.litton@miron-construction.com)>  
**Subject:** FW: [E] RE: 240830 Green Lake - Cost of work at Salt Shed

Derek,

Per our discussion today Below is the email on the OH Door (400E) that apparently Modern OH Door did not include in their bid. Also attached is the history of this issue and the three low bidders. I can provide any of the information we reviewed on site today. Once you have a chance to review this issue with your team please reach out so I can work with Modern to resolve this issue.

Thank you,

**From:** [jim@modernoverhead.com](mailto:jim@modernoverhead.com) <[jim@modernoverhead.com](mailto:jim@modernoverhead.com)>  
**Sent:** Tuesday, April 28, 2026 8:46 AM  
**To:** Brian Frye <[Brian.Frye@miron-construction.com](mailto:Brian.Frye@miron-construction.com)>  
**Cc:** 'Ryan Stobbe' <[ryans@modernoverhead.com](mailto:ryans@modernoverhead.com)>  
**Subject:** [E] RE: 240830 Green Lake - Cost of work at Salt Shed

**CAUTION: External Email**

Brian,

Thanks for your time this morning. Per our discussion, the value of Doors 400B & 400D are submitted in the Quote for this project but Door 400E was not in the Door Schedule on our Plan.

The value of Doors 400B & 400D (20'x23'), including Labor & Operators is \$101,279.58 (\$50,639.79 each).

The estimated value of Door 400E (16'x23') will be \$41,060.00 including labor & operator.

Thank you,  
Jim Ziehr  
North Central Door Supply  
Modern Overhead Door

**50% = \$20,530.00**

**From:** Brian Frye <[Brian.Frye@miron-construction.com](mailto:Brian.Frye@miron-construction.com)>  
**Sent:** Monday, April 27, 2026 4:40 PM  
**To:** [jim@modernoverhead.com](mailto:jim@modernoverhead.com)  
**Cc:** Ryan Stobbe <[ryans@modernoverhead.com](mailto:ryans@modernoverhead.com)>  
**Subject:** FW: 240830 Green Lake - Cost of work at Salt Shed

Jim,

As discussed, I am looking for the Labor and material cost for the OH Doors including operators and all equipment.

Central Door Proposal Review

<b>SPECIALTY DOOR SCHEDULE</b>										
DOOR NO.	DOOR LOCATION		DOOR SIZE		DOOR TYPE	FIRE RATING	ACCESS CONTROL	DOOR OPTIONS		REMARKS
	ROOM NO.	ROOM NAME	WIDTH	HEIGHT				OPERATION	LIFT	
139B	139	PARTS	12'-0"	9'-0"	OH2	--	--	3B	STD	
142B	142	REPAIR BAYS	20'-0"	16'-0"	OH2	--	--	3B, RC	HLV	
142C	142	REPAIR BAYS	20'-0"	16'-0"	OH2	--	--	3B, RC	HLV	
142D	142	REPAIR BAYS	20'-0"	16'-0"	OH2	--	--	3B, RC	HLV	
142E	142	REPAIR BAYS	20'-0"	16'-0"	OH2	--	--	3B, RC	HLV	
142F	142	REPAIR BAYS	20'-0"	16'-0"	OH2	--	--	3B, RC	HLV	
142H	142	REPAIR BAYS	20'-0"	16'-0"	OH2	--	--	3B, RC	HLV	
144A	144	TIRE STORAGE	12'-0"	16'-0"	OH2	--	--	3B, RC	HLV	
144C	144	TIRE STORAGE	12'-0"	14'-0"	OH2	--	--	3B	HLV	
145C	145	SIGN STORAGE	16'-0"	16'-0"	OH2	--	--	3B, RC	HLV	
149B	149	WASH BAY	20'-0"	16'-0"	OH3	--	--	3B, RC	HLV	S.S. TRACK AND ACCS.
149C	149	WASH BAY	20'-0"	16'-0"	OH3	--	--	3B, RC	HLV	S.S. TRACK AND ACCS.
150A	150	BRINE	12'-0"	10'-0"	OCD1	--	--	M	--	STAINLESS STEEL
151D	142	REPAIR BAYS	10'-0"	12'-0"	OCD1	--	--	3B	--	
151E	151	HEATED TRUCK STORAGE	20'-0"	16'-0"	OH2	--	--	3B, GL	HLV	
151G	151	HEATED TRUCK STORAGE	20'-0"	16'-0"	OH2	--	--	3B, GL	HLV	
151H	151	HEATED TRUCK STORAGE	20'-0"	16'-0"	OH2	--	--	3B, GL	HLV	
151J	151	HEATED TRUCK STORAGE	20'-0"	16'-0"	OH2	--	--	3B, GL	HLV	
300A	300	COLD STORAGE	24'-0"	14'-0"	OH2	--	DC	3B, RC	HLV	
300E	300	COLD STORAGE	24'-0"	14'-0"	OH2	--	DC	3B, RC	HLV	
400B	400	SALT SHED	20'-0"	23'-0"	OH1	--	--	3B	HLV	
400D	400	SALT SHED	20'-0"	23'-0"	OH1	--	--	3B	HLV	
400E	400	SALT SHED	16'-0"	23'-0"	OH1	--	--	3B	HLV	

Modern OH Door Bid \$405.00.00

Central Door Solutions (2nd Bidder) – \$412,000.00 (bid incomplete, missing 5 OH Doors (150A, 151D, 400B, 400D and 400E)

Mid-West OH Door not scoped out at \$460,000.00

## CONSTRUCTION BULLETIN

### CB #2

Project **GREEN LAKE COUNTY HIGHWAY COMMISSION**  
 Project No. **230486600**  
 Location **Princeton, WI.**  
 Date **December 5, 2025**



Provide pricing for approval if revisions result in an adjustment to the contract amount.		Requested by			
This construction bulletin to the contract documents is issued to modify, explain or correct the original documents and is hereby made part of the construction documents. All contractors shall read and become familiar with all items in this construction bulletin.		Owner	Contractor	AHJ	Excel
T1.0	Updated Sheet Index.				X
C1.1	Revised site plan per updated salt storage footprint.	X			
C1.2	Revised site grading per updated salt storage footprint.	X			
C1.3	Background updated per new salt storage footprint.				X
	Added notes for grates on culvert inlets per WI DSPS comments.			X	
C1.4B	Revised seeding limits per updated salt storage footprint.	X			
C1.4C	Revised erosion matting limits per updated salt storage footprint.	X			
C2.0	Updated gate notes per RFI.		X		
A1.1	Updated background for lean-to shift				
A1.1C	Shift lean-to Acetylene tank storage to the west to accomidate precast connection				X
A1.1G	Increased the size of the salt storage shed	X			
	Added overhead door 400E	X			
	Updated sections of the sand and salt storage shed spec	X			X
A1.3C	Shift lean-to Acetylene tank storage to the west to accomidate precast connection				X
A1.5	Added Rated Floor Hatch Spec				X
A2.0	Added signage elevation for clarification		X		X
A2.1	Added Signage elevations call out				X
A2.2	Shift lean-to Acetylene tank storage to the west to accomidate precast connection				X
	Added Signage elevations call out				X
A3.3	Updated the wording of cast stone veneer to block veneer to align with the wording on sheet A2.0				X

A3.4	Updated the wording of cast stone veneer to block veneer to align with the wording on sheet A2.0				X
A4.2	Updated precast details 16/A4.2 and 15/A4.2				X
A5.1	Added interior signage bid spec		X		X
A6.1	Updated hardware sets to reflect what is shown on electrical drawings				X
A6.2	Add note to provide 316 Stainless steel at brine room and other high corrosive environments				X
A6.3	Add note to provide 316 Stainless steel at brine room and other high corrosive environments				X
A9.1B	Updated Crane bid spec per email conversation with Miron and crane supplier				X
S1.10A	Added notes for clarity.				X
S1.10B	Added notes for clarity.				X
S1.10C	Shifted canopy per precast coordination.		X		X
S1.21B	Updated crane steel beam elevations.				X
S1.30C	Shifted canopy per precast coordination.		X		X
S1.30D	Added joist girder designations.				X
S1.30E	Shifted steel joists per precast coordination.		X		X
	Added joist girder designations.				X
S2.0	Adding missing pier type detail per shop drawing comments.				X
S2.1	Added detail				X
S2.5	Added note for clarity.				X
S3.2	Updating joist loading information.				X
S3.3	Modified detail to match other conditions.				X
S3.4	Modified details per precast coordination.		X		X
S3.5	Modified details per precast coordination.		X		X
P5.0	Updated pipe schedule.				X
H1.1E	Thermostat locations updated.				X
H1.2B	RACU-3 drain piping updated.				X
E1.1GL	Revised lighting layout for the updated salt storage layout.	X			
E1.1GPS	Revised power layout for the updated salt storage layout.	X			
	Revised a circuiting for an overhead door.	X			
	Added a power connection for overhead door.	X			

END OF CONSTRUCTION BULLETIN

**SECTION 00 41 00 - BID FORM**

**To:** Green Lake County  
571 Co Rd A  
Green Lake, WI 54941  
Attention: Derek Mashuda, Highway Commissioner  
Email Address: [dmashuda@greenlakecountywi.gov](mailto:dmashuda@greenlakecountywi.gov)  
Phone Number: 920-294-4062

**Project:** **New Highway Facility**  
**Green Lake County**  
Princeton, WI / **Bid Package 03**  
Miron Project# 240830

**Bid Date and Time:** 02/26/2026 @ 2:00 PM CST

**Bid Submitted By:**

Company Name: Modern Overhead Door Corp.  
Address: 1112 N Douglas St. Ripon, WI 54971  
Telephone Number: (920)748-5000  
Contact Person: Ryan Stobbe  
Email Address: ryans@modernoverhead.com

**Base Bid Summary:**

In compliance with the Advertisement for Bids, the undersigned hereby proposes to furnish and perform all work necessary for the completion of the listed Contract for the Green Lake County New Highway Facility project located at N4843 WI-73, Princeton, WI, 54968 in strict accordance with the Specifications and the Drawings mentioned therein, as prepared by the Architect, Excel Engineering, 100 Camelot Drive, Fond du Lac, WI 54935 dated 12/18/2025. Our bid is for the following:

<b>Contract #</b>	<b>Description</b>
<u>08.33</u>	<u>Overhead Doors</u>

Base Bid (In words and figures): Four Hundred Five Thousand Dollars  
\$ 405,000.00

Addition to Base Bid, if a 100% Performance and Payment Bond is required: **ADD \$** 10,125.00

**BID BOND Requirement:**

A bid security in the amount of five percent (5%) of the maximum amount of the Bid must accompany each bid.

Yes, a bid security is included in the cost of this bid proposal.

**Initial:** RJS



# OLD REPUBLIC SURETY COMPANY

## POWER OF ATTORNEY

KNOW ALL MEN BY THESE PRESENTS: That OLD REPUBLIC SURETY COMPANY, a Wisconsin stock insurance corporation, does make, constitute and appoint: MICHAEL J. DOUGLAS, CHRIS M. STEINAGEL, CHRISTOPHER MATHER KEMP, ROBERT S. DOWNEY, CONNIE SMITH, KORY C. MORTEL, ELIOT MOTU, SAMUEL DUCHOW of HUDSON, WI

its true and lawful Attorney(s)-in-Fact, with full power and authority for and on behalf of the company as surety, to execute and deliver and affix the seal of the company thereto (if a seal is required), bonds, undertakings, recognizances or other written obligations in the nature thereof, (other than ball bonds, bank depository bonds, mortgage deficiency bonds, mortgage guaranty bonds, guarantees of installment paper and note guaranty bonds, self-insurance workers compensation bonds guaranteeing payment of benefits, or black lung bonds), as follows:

### ALL WRITTEN INSTRUMENTS

and to bind OLD REPUBLIC SURETY COMPANY thereby, and all of the acts of said Attorneys-in-Fact, pursuant to these presents, are ratified and confirmed. This appointment is made under and by authority of the board of directors at a special meeting held on February 18, 1982.

This Power of Attorney is signed and sealed by facsimile under and by the authority of the following resolutions adopted by the board of directors of the OLD REPUBLIC SURETY COMPANY on February 18, 1982.

RESOLVED that, the president, any vice-president or assistant vice president, in conjunction with the secretary or any assistant secretary, may appoint attorneys-in-fact or agents with authority as defined or limited in the instrument evidencing the appointment in each case, for and on behalf of the company to execute and deliver and affix the seal of the company to bonds, undertakings, recognizances, and suretyship obligations of all kinds; and said officers may remove any such attorney-in-fact or agent and revoke any Power of Attorney previously granted to such person.

RESOLVED FURTHER, that any bond, undertaking, recognizance, or suretyship obligation shall be valid and binding upon the Company

- (i) when signed by the president, any vice president or assistant vice president, and attested and sealed (if a seal be required) by any secretary or assistant secretary; or
- (ii) when signed by the president, any vice president or assistant vice president, secretary or assistant secretary, and countersigned and sealed (if a seal be required) by a duly authorized attorney-in-fact or agent; or
- (iii) when duly executed and sealed (if a seal be required) by one or more attorneys-in-fact or agents pursuant to and within the limits of the authority evidenced by the Power of Attorney issued by the company to such person or persons.

RESOLVED FURTHER that the signature of any authorized officer and the seal of the company may be affixed by facsimile to any Power of Attorney or certification thereof authorizing the execution and delivery of any bond, undertaking, recognizance, or other suretyship obligations of the company; and such signature and seal when so used shall have the same force and effect as though manually affixed.

IN WITNESS WHEREOF, OLD REPUBLIC SURETY COMPANY has caused these presents to be signed by its proper officer, and its corporate seal to be affixed this 22nd day of September, 2022

Karen J. Hoffner  
Assistant Secretary



OLD REPUBLIC SURETY COMPANY

Alan Pavlic  
President

STATE OF WISCONSIN, COUNTY OF WAUKESHA - SS

On this 22nd day of September, 2022, personally came before me, Alan Pavlic and Karen J Hoffner, to me known to be the individuals and officers of the OLD REPUBLIC SURETY COMPANY who executed the above instrument, and they each acknowledged the execution of the same, and being by me duly sworn, did severally depose and say: that they are the said officers of the corporation aforesaid, and that the seal affixed to the above instrument is the seal of the corporation, and that said corporate seal and their signatures as such officers were duly affixed and subscribed to the said instrument by the authority of the board of directors of said corporation.



Kathryn R. Pearson  
Notary Public

My Commission Expires: September 28, 2026

(Expiration of notary's commission does not invalidate this instrument)

### CERTIFICATE

I, the undersigned, assistant secretary of the OLD REPUBLIC SURETY COMPANY, a Wisconsin corporation, CERTIFY that the foregoing and attached Power of Attorney remains in full force and has not been revoked; and furthermore, that the Resolutions of the board of directors set forth in the Power of Attorney, are now in force.

24-5172



Signed and sealed at the City of Brookfield, WI this 29th day of January, 2026

Karen J. Hoffner  
Assistant Secretary

ORSC 22262 (3-06)

J. RYAN BONDING, INC.

# GRANITE RE, INC.

## Bid Bond

KNOW ALL MEN BY THESE PRESENTS, that we Modern Overhead Door, Corp  
1112 N Douglas St, Ripon, WI 54971

as principal, hereinafter called the Principal, and **Granite Re, Inc., 14001 Quailbrook Drive, Oklahoma City, OK 73134**,  
a corporation duly organized under the laws of the State of Minnesota as Surety, hereinafter called the Surety, are held  
and firmly bound unto Miron Construction Co., Inc. - WI

1471 McMahan Dr, Neenah, WI 54956

as Obligee, hereinafter called the Obligee, in the sum of \*\*\*\* Five Percent of Bid Amount (5%) \*\*\*\*

for payment of which sum well and truly to be made, the said Principal and the said Surety, bind ourselves, our heirs,  
executors, administrators, successors and assigns, jointly and severally, firmly by these presents.

WHEREAS, the Principal has submitted a bid for

Project: Green Lake County - New Highway Facility, N 4843 Hwy 73, Princeton, WI 54968 / #08.33 - Overhead Doors /  
240830

Bid Date: 02/26/2026

The conditions of this Bond are such that if the Obligee accepts the bid of the Principal within the time specified in the bid documents or within such time period as may be agreed to by the Obligee and Principal, and the Principal either (1) enters into a contract with the Obligee in accordance with the terms of such bid, and gives such bond or bonds as may be specified in the bidding or Contract Documents, with a surety admitted in the jurisdiction of the Project and otherwise acceptable to the Obligee, for the faithful performance of such Contract and for the prompt payment of labor and material furnished in the prosecution thereof; or (2) pays to the Obligee the difference, not to exceed the amount of this Bond, between the amount specified in said bid and such larger amount for which the Obligee may in good faith contract with another party to perform the work covered by said bid, then this obligation shall be null and void, otherwise to remain in full force and effect. The Surety hereby waives any notice of an agreement between the Obligee and Principal to extend the time in which the Obligee may accept the bid. Waiver of notice by the Surety shall not apply to any extension exceeding sixty (60) days in the aggregate beyond the time for acceptance of bids, and the Obligee and Principal shall obtain the Surety's consent for an extension beyond sixty (60) days.

When this Bond has been furnished to comply with a statutory or other legal requirement in the location of the Project, any provision in this Bond conflicting with said statutory or legal requirement shall be deemed deleted herefrom and provisions conforming to such statutory or other legal requirement shall be deemed incorporated herein. When so furnished, the intent is that this bond shall be construed as a statutory bond and not as a common law bond.

Signed and sealed this 02/26/2026

Witness 

Modern Overhead Door, Corp  
  
Title president (SEAL)

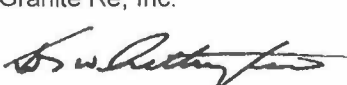
Granite Re, Inc.  
  
Kenneth D. Whittington, Attorney-in-Fact (SEAL)



# OLD REPUBLIC SURETY COMPANY

## POWER OF ATTORNEY

KNOW ALL MEN BY THESE PRESENTS: That OLD REPUBLIC SURETY COMPANY, a Wisconsin stock insurance corporation, does make, constitute and appoint: MICHAEL J. DOUGLAS, CHRIS M. STEINAGEL, CHRISTOPHER MATHER KEMP, ROBERT S. DOWNEY, CONNIE SMITH, KORY C. MORTEL, ELIOT MOTU, SAMUEL DUCHOW of HUDSON, WI

its true and lawful Attorney(s)-in-Fact, with full power and authority for and on behalf of the company as surety, to execute and deliver and affix the seal of the company thereto (if a seal is required), bonds, undertakings, recognizances or other written obligations in the nature thereof, (other than bail bonds, bank depository bonds, mortgage deficiency bonds, mortgage guaranty bonds, guarantees of installment paper and note guaranty bonds, self-insurance workers compensation bonds guaranteeing payment of benefits, or black lung bonds), as follows:

### ALL WRITTEN INSTRUMENTS

and to bind OLD REPUBLIC SURETY COMPANY thereby, and all of the acts of said Attorneys-in-Fact, pursuant to these presents, are ratified and confirmed. This appointment is made under and by authority of the board of directors at a special meeting held on February 18, 1982.

This Power of Attorney is signed and sealed by facsimile under and by the authority of the following resolutions adopted by the board of directors of the OLD REPUBLIC SURETY COMPANY on February 18, 1982.

RESOLVED that, the president, any vice-president or assistant vice president, in conjunction with the secretary or any assistant secretary, may appoint attorneys-in-fact or agents with authority as defined or limited in the instrument evidencing the appointment in each case, for and on behalf of the company to execute and deliver and affix the seal of the company to bonds, undertakings, recognizances, and suretyship obligations of all kinds; and said officers may remove any such attorney-in-fact or agent and revoke any Power of Attorney previously granted to such person.

RESOLVED FURTHER, that any bond, undertaking, recognizance, or suretyship obligation shall be valid and binding upon the Company

- (i) when signed by the president, any vice president or assistant vice president, and attested and sealed (if a seal be required) by any secretary or assistant secretary; or
- (ii) when signed by the president, any vice president or assistant vice president, secretary or assistant secretary, and countersigned and sealed (if a seal be required) by a duly authorized attorney-in-fact or agent; or
- (iii) when duly executed and sealed (if a seal be required) by one or more attorneys-in-fact or agents pursuant to and within the limits of the authority evidenced by the Power of Attorney issued by the company to such person or persons.

RESOLVED FURTHER that the signature of any authorized officer and the seal of the company may be affixed by facsimile to any Power of Attorney or certification thereof authorizing the execution and delivery of any bond, undertaking, recognizance, or other suretyship obligations of the company; and such signature and seal when so used shall have the same force and effect as though manually affixed.

IN WITNESS WHEREOF, OLD REPUBLIC SURETY COMPANY has caused these presents to be signed by its proper officer, and its corporate seal to be affixed this 22nd day of September, 2022

Karen J. Halfner  
Assistant Secretary



OLD REPUBLIC SURETY COMPANY

Alan Pavlic  
President

STATE OF WISCONSIN, COUNTY OF WAUKESHA - SS

On this 22nd day of September, 2022, personally came before me, Alan Pavlic and Karen J Halfner, to me known to be the individuals and officers of the OLD REPUBLIC SURETY COMPANY who executed the above instrument, and they each acknowledged the execution of the same, and being by me duly sworn, did severally depose and say: that they are the said officers of the corporation aforesaid, and that the seal affixed to the above instrument is the seal of the corporation, and that said corporate seal and their signatures as such officers were duly affixed and subscribed to the said instrument by the authority of the board of directors of said corporation.



Kathryn R. Pearson  
Notary Public

My Commission Expires: September 28, 2026

(Expiration of notary's commission does not invalidate this instrument)

### CERTIFICATE

I, the undersigned, assistant secretary of the OLD REPUBLIC SURETY COMPANY, a Wisconsin corporation, CERTIFY that the foregoing and attached Power of Attorney remains in full force and has not been revoked; and furthermore, that the Resolutions of the board of directors set forth in the Power of Attorney, are now in force.

24-5172

Signed and sealed at the City of Brookfield, WI this 29th day of January, 2026

Karen J. Halfner  
Assistant Secretary



ORSC 22262 (3-06)

J. RYAN BONDING, INC.

**SECTION 00 41 00 - BID FORM**

To: Green Lake County  
571 Co Rd A  
Green Lake, WI 54941  
Attention: Derek Mashuda, Highway Commissioner  
Email Address: dmashuda@greenlakecountywi.gov  
Phone Number: 920-294-4062

Project: **New Highway Facility**  
**Green Lake County**  
Princeton, WI / **Bid Package 02**  
Miron Project# 240830

**Bid Date and Time:** 12/16/2025 @ 2:00 PM CST

**Bid Submitted By:**

Company Name: Central Door Solutions  
Address: 1430 Contractors Blvd, Plover Wi 54467  
Telephone Number: 715-340-1505  
Contact Person: Brian Mefferd  
Email Address: bmefferd@centraldoorsolutions.com

**Base Bid Summary:**

In compliance with the Advertisement for Bids, the undersigned hereby proposes to furnish and perform all work necessary for the completion of the listed Contract for the Green Lake County New Highway Facility project located at N4843 WI-73, Princeton, WI, 54968 in strict accordance with the Specifications and the Drawings mentioned therein, as prepared by the Architect, Excel Engineering, 100 Camelot Drive, Fond du Lac, WI 54935 dated 10/29/2025. Our bid is for the following:

Contract #	Description
<u>08.33 -</u>	<u>Overhead Doors</u>

Base Bid (In words and figures): four hundred twelve thousand Dollars  
\$ 412,000.00

Addition to Base Bid, if 100% Performance and Payment Bond is Required: ADD \$ 18,500.00

**BID BOND Requirement:**

A bid security in the amount of five percent (5%) of the maximum amount of the Bid must accompany each bid.

Yes, a bid security is included in the cost of this bid proposal. **Initial:** BM

**SECTION 00 41 00 - BID FORM**

2.	Provide a unit cost \$/SF for moisture mitigation.		n/a
3.			

**Labor Rates:**

Provide labor rates below for each applicable trade. Rates should be inclusive of all base wages, fringes, benefits, per diems, travel costs, and markups.

Trade	OHD Installer - (non-union)	ST Rate (\$/hr)	OT Rate (\$/hr)
Foreman		149.00	224.00
Journeyman		149.00	224.00
Apprentice		149.00	224.00

Trade		ST Rate (\$/hr)	OT Rate (\$/hr)
Foreman			
Journeyman			
Apprentice			

Trade		ST Rate (\$/hr)	OT Rate (\$/hr)
Foreman			
Journeyman			
Apprentice			

**Schedule of Work:**

Time is of the essence. Contractor agrees to commence and complete the work in a timely fashion as indicated on the master project schedule. Within five (5) working days of award, Contractor shall provide Miron a complete list of long lead items, submittal schedule, fabrication durations and installation durations for incorporation into the detailed project schedule.

**Key Project Personnel:**

For contracts in excess of \$100,000, Contractor shall identify the names of their key personnel who will be assigned to the project.

Project Manager: Dave Carpenter

Lead Foreman: TBD

**Bid Form Signatures:**

Authorized Signature: 

Printed/Typed Name: Brian Mefferd

Title: Account Manager

Date: 12/16/25

--- END OF BID FORM ---



# AIA Document A310™ – 2010

## Bid Bond

**CONTRACTOR:**

*(Name, legal status and address)*

Central Door Solutions LLC

1430 Contractors Blvd  
Plover, WI 54467-2609

**OWNER:**

*(Name, legal status and address)*

Green Lake County  
N4843 Highway 73  
Princeton, WI 54968-8635

**SURETY:**

*(Name, legal status and principal place of business)*

West Bend Insurance Company  
1900 S 18th Ave  
West Bend, WI 53095-8796

**ADDITIONS AND DELETIONS:**

The author of this document has added information needed for its completion. The author may also have revised the text of the original AIA standard form. An *Additions and Deletions Report* that notes added information as well as revisions to the standard form text is available from the author and should be reviewed. A vertical line in the left margin of this document indicates where the author has added necessary information and where the author has added to or deleted from the original AIA text.

This document has important legal consequences. Consultation with an attorney is encouraged with respect to its completion or modification.

Any singular reference to Contractor, Surety, Owner or other party shall be considered plural where applicable.

**BOND AMOUNT:** \$ Five Percent of the Bid Amount

**PROJECT:**

*(Name, location or address, and Project number, if any)*

Green Lake County New Highway Facility

The Contractor and Surety are bound to the Owner in the amount set forth above, for the payment of which the Contractor and Surety bind themselves, their heirs, executors, administrators, successors and assigns, jointly and severally, as provided herein. The conditions of this Bond are such that if the Owner accepts the bid of the Contractor within the time specified in the bid documents, or within such time period as may be agreed to by the Owner and Contractor, and the Contractor either (1) enters into a contract with the Owner in accordance with the terms of such bid, and gives such bond or bonds as may be specified in the bidding or Contract Documents, with a surety admitted in the jurisdiction of the Project and otherwise acceptable to the Owner, for the faithful performance of such Contract and for the prompt payment of labor and material furnished in the prosecution thereof; or (2) pays to the Owner the difference, not to exceed the amount of this Bond, between the amount specified in said bid and such larger amount for which the Owner may in good faith contract with another party to perform the work covered by said bid, then this obligation shall be null and void, otherwise to remain in full force and effect. The Surety hereby waives any notice of an agreement between the Owner and Contractor to extend the time in which the Owner may accept the bid. Waiver of notice by the Surety shall not apply to any extension exceeding sixty (60) days in the aggregate beyond the time for acceptance of bids specified in the bid documents, and the Owner and Contractor shall obtain the Surety's consent for an extension beyond sixty (60) days.

If this Bond is issued in connection with a subcontractor's bid to a Contractor, the term Contractor in this Bond shall be deemed to be Subcontractor and the term Owner shall be deemed to be Contractor.

When this Bond has been furnished to comply with a statutory or other legal requirement in the location of the Project, any provision in this Bond conflicting with said statutory or legal requirement shall be deemed deleted herefrom and provisions conforming to such statutory or other legal requirement shall be deemed incorporated herein. When so furnished, the intent is that this Bond shall be construed as a statutory bond and not as a common law bond.

Init.



Bond No. 2664620

**POWER OF ATTORNEY**

Know all men by these Presents, that West Bend Insurance Company (formerly known as West Bend Mutual Insurance Company prior to 1/1/2024), a corporation having its principal office in the City of West Bend, Wisconsin does make, constitute and appoint:

Stephanie A Gruling

lawful Attorney(s)-in-fact, to make, execute, seal and deliver for and on its behalf as surety and as its act and deed any and all bonds, undertakings and contracts of suretyship, provided that no bond or undertaking or contract of suretyship executed under this authority shall exceed in amount the sum of: Thirty Million Dollars (\$30,000,000)

This Power of Attorney is granted and is signed and sealed by facsimile under and by the authority of the following Resolution adopted by the Board of Directors of West Bend Insurance Company by unanimous consent resolution effective the 1<sup>st</sup> day of January 2024.

*Appointment of Attorney-In-Fact. The president or any vice president, or any other officer of West Bend Insurance Company may appoint by written certificate Attorneys-In-Fact to act on behalf of the company in the execution of and attesting of bonds and undertakings and other written obligatory instruments of like nature. The signature of any officer authorized hereby and the corporate seal may be affixed by facsimile to any such power of attorney or to any certificate relating therefore and any such power of attorney or certificate bearing such facsimile signatures or facsimile seal shall be valid and binding upon the company, and any such power so executed and certified by facsimile signatures and facsimile seal shall be valid and binding upon the company in the future with respect to any bond or undertaking or other writing obligatory in nature to which it is attached. Any such appointment may be revoked, for cause, or without cause, by any said officer at any time.*

Any reference to West Bend Mutual Insurance Company in any Bond and all continuations thereof shall be considered a reference to West Bend Insurance Company.

In witness whereof, West Bend Insurance Company has caused these presents to be signed by its president undersigned and its corporate seal to be hereto duly attested by its secretary this 1st day of January 2024.

Attest Christopher C. Zwygart  
Christopher C. Zwygart  
Secretary



Robert J. Jacques  
Robert J. Jacques  
President

State of Wisconsin  
County of Washington

On the 1<sup>st</sup> day of January 2024, before me personally came Robert Jacques, to me known being by duly sworn, did depose and say that he is the President of West Bend Insurance Company, the corporation described in and which executed the above instrument; that he knows the seal of the said corporation; that the seal affixed to said instrument is such corporate seal; that it was so affixed by order of the board of directors of said corporation and that he signed his name thereto by like order.

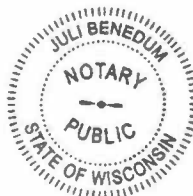

Jul Benedum  
Lead Corporate Attorney  
Notary Public, Washington Co., WI  
My Commission is Permanent

The undersigned, duly elected to the office stated below, now the incumbent in West Bend Insurance Company, a Wisconsin corporation authorized to make this certificate, Do Hereby Certify that the foregoing attached Power of Attorney remains in full force effect and has not been revoked and that the Resolution of the Board of Directors, set forth in the Power of Attorney is now in force.

Signed and sealed at West Bend, Wisconsin this 15th day of December, 2025



Christopher C. Zwygart  
Christopher C. Zwygart  
Secretary



Central Door Solutions  
 1430 Contractors Blvd  
 Plover, WI 54467  
 (715) 342-4153

Estimate 50662646  
 Estimate Date 2/24/2026

**Billing Address**

Green Lake County- New Highway Facility  
 N4843 Wisconsin 73  
 Princeton, WI 54968 USA

**Job Address**

Green Lake County- New Highway Facility  
 N4843 Wisconsin 73  
 Princeton, WI 54968 USA

Service #	Description	Total
Brian Mefferd	Rep: Brian Mefferd bmefferd@centraldoorsolutions.com 715-340-1505	
Clarifications:	Clarifications: -ELECTRICAL AND CONDUIT BY OTHERS -PREWIREING OF OPERATORS EXCLUDED -ANY JAMB WRAPS, STRUCTURAL BLOCKING, COUNTERTOPS, THRESHOLDS EXCLUDED -2 ADDENDUMS -TAX EXEMPT -PREVAILING WAGES EXCLUDED	
Sale Com Mat Custom	Materials & Installation of Overhead Doors & Operators  QTY (1) MARK: 139B SIZE: 12'-2" X 9'-0" RO: 12'-0" X 9'-0" (STANDARD LIFT) QTY (10) MARK: 142B, 142C, 142D, 142E, 142F, 142H, 151E, 151G, 151H, 151J SIZE: 20'-2" X 16'-0" RO: 20'-0" X 16'-0" QTY (1) MARK: 144A SIZE: 12'-2" X 16'-0" RO: 12'-0" X 16'-0" QTY (1) MARK: 144C SIZE: 12'-2" X 14'-0" RO: 12'-0" X 14'-0" QTY (1) MARK: 145C SIZE: 16'-2" X 16'-0" RO: 16'-0" X 16'-0" QTY (2) MARK: 300A, 300E SIZE: 24'-2" X 14'-0" RO: 24'-0" X 14'-0" MODEL : CLOPAY 3717 1 3/4" 27GA INSULATION : POLYURETHANE R16.2 WIND LOAD DESIGN PRESSURE : +25, -28 COLOR : STANDARD WHITE GLASS TYPE : INSULATED CLEAR ACRYLIC, SECTION 3 FRAMING : 24 X 8 (SIZE REQUIRED FOR WIND LOADING) SPRING : TORSION 50K CYCLES TRACK SIZE : 3" FULL TAPERED TRACK MOUNT : REVERSE ANGLE TRACK LIFT : HIGH LIFT TRACK RADIUS : BREAKAWAY ADDITIONAL OPTIONS : EXTENDED SOLID SHAFT AT HIGH LIFT DOORS SEAL: FULL PERIMETER CLIP ON SEAL  QTY (2) MARK: 149B, 149C SIZE: 20'-2" X 16'-0" RO: 20'-0" X 16'-0" MODEL : CLOPAY 904U ALUMINUM INSULATION : POLYURETHANE FILLED FRAMING WIND LOAD DESIGN PRESSURE : +25, -27.5 COLOR : STANDARD WHITE GLASS TYPE : INSULATED CLEAR ACRYLIC, FULL VIEW SPRING : TORSION 50K CYCLES TRACK SIZE : 3" FULL TAPERED W/ STAINLESS TRACK AND HARDWARE TRACK MOUNT : REVERSE ANGLE TRACK LIFT : HIGH LIFT TRACK RADIUS : BREAKAWAY ADDITIONAL OPTIONS : EXTENDED SOLID SHAFT	\$415,000.00

Sale Com Mat	Performance and Payment Bond	\$18,700.00
Custom		

---

<b>Sub-Total</b>	\$433,700.00
<b>Tax</b>	\$0.00
<b>Total Due</b>	\$433,700.00

50% Down at time of order. A 3.5% Transaction Fee will be added to all invoices if paying by Card at the time of payment. Balance due upon completion of job. Unpaid balances will result in additional charges associated with collection of payment. Checks made payable to Central Door Solutions LLC. No painting, electrical wiring, preparation of openings(jambes or support pads)is included in this price unless indicated. If cancelled there is a 50% restock fee.

---

THIS IS AN ESTIMATE, NOT A CONTRACT FOR SERVICES. The summary above is furnished by Central Door Solutions as a good faith estimate of work to be performed at the location described above and is based on our evaluation and does not include material price increases or additional labor and materials which may be required should unforeseen problems arise after the work has started. I understand that the final cost of the work may differ from the estimate, perhaps materially. THIS IS NOT A GUARANTEE OF THE FINAL PRICE OF WORK TO BE PERFORMED. I agree and authorize the work as summarized on these estimated terms, and I agree to pay the full amount for all work performed.



PO Box 1517  
 Fond du Lac, WI 54936-1517  
 (920) 922-9549  
 mwoverheaddoor@gmail.com

# Estimate

<b>ESTIMATE#</b>	10821586
<b>DATE</b>	02/23/2026
<b>PO#</b>	Green Lake New HWY Facility

<b>CUSTOMER</b>
Green Lake County 571 County Road A Green Lake WI 54941 (920) 294-4064 (M) Green Lake County

<b>SERVICE LOCATION</b>
New Highway Facility N4843 Hwy 73 Princeton WI 54968

DESCRIPTION	
1- Clopay 3717, 12-2X9	
10- Clopay 3717, 20-2X16	
1- Clopay 3717, 12-2X16	
1- Clopay 3717, 12-2X14	
1- Clopay 3717, 16-2X16	
2- Clopay 3717, 20-2X16	
1- Clopay CESD20, 12X10 Ins. Coiling, Stainless	
1- Clopay CESD20, 10X12 Ins. Coiling, With Opener	
2- Clopay 3717, 24-2X14	
2- Survivor Polycarbonate 20-2X23	
1- Survivor Polycarbonate 16-2X23	
21- Commercial 3 Phase Openers with 40- 893LM Remotes and also supply Ground Loop	

## Estimate

Description	Qty	Rate	Total
Clopay3717 Clopay Model 3717 Series Steel Insulated R-Value 16.2 - Size: 12-2X9 - Track: 2 Inch Reverse Angle Mount NH T12 - Color: White - Windows: Insulated Glass 24X12 in section 3 - Torsion Springs 50,000 Cycles - Header and Jamb Seal - Installation	1.00	0.00	0.00
DOOR: 139B			
Clopay3717 Clopay Model 3717 Series Steel Insulated R-Value 16.2 - Size: 20-2X16 - Track: 3 Inch Reverse Angle Mount 120" of Lift - Color: White - Windows: Insulated Glass 24X12 in section 3 - Torsion Springs 50,000 Cycles - Header and Jamb Seal - Installation	6.00	0.00	0.00
DOORS: 142B, 142C, 142D, 142E, 142F, 142H			
Clopay3717 Clopay Model 3717 Series Steel Insulated R-Value 16.2 - Size: 12-2X16 - Track: 3 Inch Reverse Angle Mount 120" of Lift - Color: White - Windows: Insulated Glass 24X12 in section 3 - Torsion Springs 50,000 Cycles - Header and Jamb Seal - Installation	1.00	0.00	0.00
DOOR: 144A			

Description	Qty	Rate	Total
LIFTMASTER-Non-inventory Liftmaster J103L5 Jackshaft Opener - 1HP, 3 Phase 460 Volt - 3 Button Wall Station (open, close, stop) - Light Curtain LC36M Sensing Control UL325 Listed - Installation	15.00	0.00	0.00
LIFTMASTER-Non-inventory Liftmaster T103 L5 10' Trolley Opener - 1HP, 3 Phase 460 Volt - 3 Button Wall Station (open, close, stop) - Light Curtain LC36M Sensing Control UL325 Listed - Installation	1.00	0.00	0.00
LIFTMASTER-Non-inventory Liftmaster CJ103L5 Damp Environment Jackshaft Opener - 1HP, 3 Phase 460 Volt - 3 Button Wall Station (open, close, stop) - Nema 4 CPS-UN4 Photo Eyes Sensing Control UL325 Listed - Installation	5.00	0.00	0.00
893LM My Q 893LM My Q	40.00	0.00	0.00
Misc (Non-Inventory) Part Loop Detection for Vehicle Storage Doors: 151E, 151G, 151H and 151J	1.00	0.00	0.00
Misc (Non-Inventory) Part LOT PRICING FOR ALL MATERIAL AND LABOR TO COMPLETE JOB FOR ALL OVERHEAD DOORS AND COILING DOORS AND OPENERS AND SUPPLYING THE GROUND LOOP TO THE ELECTRICIAN.	1.00	460,000.00	460,000.00

**CUSTOMER MESSAGE**

All Prices include all material and installation labor. Quote is based upon information given by customer. It is the responsibility of the customer to review the quote for accuracy and notify us of any changes prior to signing of this estimate. Any changes could affect the price of this quote. Midwest Overhead does not do any Electrical Wiring. This must be done by a licensed Electrician. This quote is Valid for 30 days.

**Estimate Total:**

**\$460,000.00**

**PRE-WORK SIGNATURE**

Signed By:

**SECTION 00 41 00 - BID FORM**

**Addenda:**

The following Addenda are acknowledged and modifications noted therein have been incorporated into the Bid.

Addendum # 1 Dated 1-27-26 Addendum # \_\_\_\_\_ Dated \_\_\_\_\_  
 Addendum # 2 Dated 2-9-26 Addendum # \_\_\_\_\_ Dated \_\_\_\_\_

**Mandatory Alternates:**

The following items may be added or deducted from the Base Bid. Alternates will be considered add alternates if not noted otherwise. Alternates left blank will be considered no change in cost to this bid proposal.

Alt. No.	Description	Amount	Add/Deduct
1.	Concrete in lieu of Heavy-Duty Asphalt	\$	
2.	Heated Truck Storage Slab Finish SC-3 in lieu of SC-2	\$	
3.	Pond Liner Alternate (HDPE in lieu of Clay)	\$	
4.	Aluminum Feeders in lieu of Copper	\$	
5.	Heated Truck Storage PAINT Ceiling	\$	
6.	Heated Truck Storage PAINT Walls	\$	
7.	Stainless Steel Piping in Wash Bay & Brine	\$	
8.	Lighted Bollards at Main Entrance Parking Lot	\$	
9.	Stainless Steel Door Frames Areas B, C, D, E, & F	\$	
10.	Armor Clad Coating on Trench Drain Grates	\$	

**Voluntary Alternates:**

Contractors are encouraged to suggest voluntary alternates or value engineering ideas. These items may be considered in the evaluation of bids. Provide description and cost impacts in space provided. Attach additional information as required to properly evaluate their inclusion into the project. Include anticipated impacts to other trades work in an attached narrative, if applicable.

Alt. No.	Description	Amount	Add/Deduct
1.			
2.			
3.			

**Insurance Requirements:**

Contractor has read and agrees to conform with the insurance requirements for the Project as required per Specification Section 00 73 16 – Insurance Requirements.

Yes, the Insurance Requirements are met and are included in the base bid value.

**Unit Prices:**

Unit prices shall include all costs for materials, labor, installation, equipment, taxes, overhead, and profit. Significant changes to the Contractor's scope may be negotiated on an individual basis.

Unit Price	Description	Add	Deduct
1.	Removal and replacement of unsuitable soil with engineered fill. (\$/CY).		
2.	Provide a unit cost \$/SF for moisture mitigation.		

# Western Surety Company

## POWER OF ATTORNEY - CERTIFIED COPY

Bond No. 67789922

Know All Men By These Presents, that WESTERN SURETY COMPANY, a corporation duly organized and existing under the laws of the State of South Dakota, and having its principal office in Sioux Falls, South Dakota (the "Company"), does by these presents make, constitute and appoint Carl Joseph Kisely

its true and lawful attorney(s)-in-fact, with full power and authority hereby conferred, to execute, acknowledge and deliver for and on its behalf as Surety, bonds for:

Principal: Midwest Overhead Door Inc

Obligee: County of Green Lake

Amount: \$1,000,000.00

and to bind the Company thereby as fully and to the same extent as if such bonds were signed by the Vice President, sealed with the corporate seal of the Company and duly attested by its Secretary, hereby ratifying and confirming all that the said attorney(s)-in-fact may do within the above stated limitations. Said appointment is made under and by authority of the following bylaw of Western Surety Company which remains in full force and effect.

"Section 7. All bonds, policies, undertakings, Powers of Attorney or other obligations of the corporation shall be executed in the corporate name of the Company by the President, Secretary, any Assistant Secretary, Treasurer, or any Vice President or by such other officers as the Board of Directors may authorize. The President, any Vice President, Secretary, any Assistant Secretary, or the Treasurer may appoint Attorneys in Fact or agents who shall have authority to issue bonds, policies, or undertakings in the name of the Company. The corporate seal is not necessary for the validity of any bonds, policies, undertakings, Powers of Attorney or other obligations of the corporation. The signature of any such officer and the corporate seal may be printed by facsimile."

This Power of Attorney may be signed by digital signature and sealed by a digital or otherwise electronic-formatted corporate seal under and by the authority of the following Resolution adopted by the Board of Directors of the Company by unanimous written consent dated the 27th day of April, 2022:

"RESOLVED: That it is in the best interest of the Company to periodically ratify and confirm any corporate documents signed by digital signatures and to ratify and confirm the use of a digital or otherwise electronic-formatted corporate seal, each to be considered the act and deed of the Company."

If Bond No. 67789922 is not issued on or before midnight of May 30th, 2026, all authority conferred in this Power of Attorney shall expire and terminate.

In Witness Whereof, Western Surety Company has caused these presents to be signed by its Vice President, Larry Kasten, and its corporate seal to be affixed this 1st day of March, 2026.

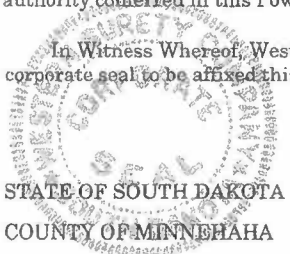

WESTERN SURETY COMPANY

Larry Kasten  
Larry Kasten, Vice President

On this 1st day of March, in the year 2026, before me, a notary public, personally appeared Larry Kasten, who being to me duly sworn, acknowledged that he signed the above Power of Attorney as the aforesaid officer of WESTERN SURETY COMPANY and acknowledged said instrument to be the voluntary act and deed of said corporation.

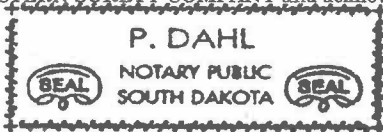

My Commission Expires June 18, 2031

P. Dahl  
Notary Public - South Dakota

I the undersigned officer of Western Surety Company, a stock corporation of the State of South Dakota, do hereby certify that the attached Power of Attorney is in full force and effect and is irrevocable, and furthermore, that Section 7 of the bylaws of the Company as set forth in the Power of Attorney is now in force.

In testimony whereof, I have hereunto set my hand and seal of Western Surety Company this 1st day of March, 2026.

WESTERN SURETY COMPANY

Larry Kasten  
Larry Kasten, Vice President

To validate bond authenticity, go to [www.cnasurety.com](http://www.cnasurety.com) > Owner/Obligee Services > Validate Bond Coverage.

**SECTION 00 41 00 - BID FORM**

To: Green Lake County  
571 Co Rd A  
Green Lake, WI 54941  
Attention: Derek Mashuda, Highway Commissioner  
Email Address: dmashuda@greenlakecountywi.gov  
Phone Number: 920-294-4062

Project: **New Highway Facility**  
**Green Lake County**  
Princeton, WI / Bid Package 03  
Miron Project# 240830

Bid Date and Time: 02/26/2026 @ 2:00 PM CST

**Bid Submitted By:**

Company Name: EZ Glide Doors  
Address: 1700 E. North Ave P.O. Box 3 Little Chute, WI 54140  
Telephone Number: 920-788-3561  
Contact Person: Dave Schommer  
Email Address: dave.schommer@ezglideinc.com

**Base Bid Summary:**

In compliance with the Advertisement for Bids, the undersigned hereby proposes to furnish and perform all work necessary for the completion of the listed Contract for the Green Lake County New Highway Facility project located at N4843 WI-73, Princeton, WI, 54968 in strict accordance with the Specifications and the Drawings mentioned therein, as prepared by the Architect, Excel Engineering, 100 Camelot Drive, Fond du Lac, WI 54935 dated 12/18/2025. Our bid is for the following:

Contract #	Description
<u>08.33</u>	<u>Overhead Coiling Door</u>
<u>Overhead</u>	<u>Sectional Overhead Door</u>
<u>Doors</u>	<u>Alum Overhead Door</u>
<u>BP-03</u>	<u>Translucent Polycarbonate Overhead Door</u>

Base Bid (In words and figures): two hundred sixty seven thousand one hundred twenty Dollars  
\$ 267,120<sup>00</sup>

Addition to Base Bid, if a 100% Performance and Payment Bond is required: ADD \$ 4007<sup>00</sup>

**BID BOND Requirement:**

A bid security in the amount of five percent (5%) of the maximum amount of the Bid must accompany each bid.

Yes, a bid security is included in the cost of this bid proposal.

Initial: DS

**SECTION 00 41 00 - BID FORM**

3.			
----	--	--	--

**Labor Rates:**

Provide labor rates below for each applicable trade. Rates should be inclusive of all base wages, fringes, benefits, per diems, travel costs, and markups.

Trade	ST Rate (\$/hr)	OT Rate (\$/hr)
Foreman	N/A	
Journeyman		
Apprentice		

Trade	ST Rate (\$/hr)	OT Rate (\$/hr)
Foreman		
Journeyman		
Apprentice		

Trade	ST Rate (\$/hr)	OT Rate (\$/hr)
Foreman		
Journeyman		
Apprentice		

**Schedule of Work:**

Time is of the essence. Contractor agrees to commence and complete the work in a timely fashion as indicated on the master project schedule. Within five (5) working days of award, Contractor shall provide Miron a complete list of long lead items, submittal schedule, fabrication durations and installation durations for incorporation into the detailed project schedule.

**Key Project Personnel:**

For contracts in excess of \$100,000, Contractor shall identify the names of their key personnel who will be assigned to the project.

Project Manager:     Dave Schommer      
 Lead Foreman:     N/A    

**Bid Form Signatures:**

Authorized Signature:   
 Printed/Typed Name:     David Schommer      
 Title:     Owner / Proj. Mgr.      
 Date:     2/24/20    

--- END OF BID FORM ---

Quote

EZ Glide Garage Doors & Openers  
P. O. Box 3  
1700 E. North Avenue  
Little Chute, WI 54140-0003  
(800)372-3667 (920)788-3561  
(920)788-3564 (fax)

Quote Number: 0054289  
Quote Date: 2/25/2026

Customer Number: 01-M2222  
Telephone #:  
Fax #: 920-751-8150  
miron@mironconst.com

MIRON CONSTRUCTION CO., INC.  
P.O. BOX 509  
NEENAH, WI 54957  
Confirm To:

Job Address:  
GREENLAKE CTY HIGHWAY COMMISSION  
N4843 WI-73  
PRINCETON, WI 54968

Estimator	Quote Expires	F.O.B.	Terms
DAVE S.	3/27/2026		NET 15 DAYS

**SECTIONAL DOORS**  
**\*ALTERNATE TO SPEC\***

- TEN (10) - 20' X 16' EZ THERM W/THREE (3) LITES - WHITE
- TWO (2) - 24' X 14' EZ THERM W/THREE (3) LITES - WHITE
- ONE (1) - 16' X 16' EZ THERM W/THREE (3) LITES - WHITE
- ONE (1) - 12' X 14' EZ THERM W/THREE (3) LITES - WHITE
- ONE (1) - 12' X 16' EZ THERM W/THREE (3) LITES - WHITE
- ONE (1) - 12' X 9' EZ THERM W/THREE (3) LITES - WHITE

- 3" HIGH LIFT TRACK
- HIGH CYCLE TORSION SPRINGS
- CONTINUOUS ANGLE W/WEATHER SEAL

**SIXTEEN (16) - HEAVY DUTY 3/4 H.P. JACKSHAFT OPERATOR**

- 460/3/60
- PHOTO EYES
- 3 BUTTON WALL STATION

**OPTION: GROUND LOOP & DETECTOR (SUPPLIED ONLY)... ADD \$400.00 EACH**

**INSTALLED BY EZ GLIDE... \$136,620.00 NO TAX**

**\*ALL ELECTRICAL WORK, LOW-VOLTAGE WIRING, CONDUIT AND CONNECTIONS BY OTHERS\***

**Order Total: 136,620.00**

All material is guaranteed to be as specified. All work to be completed in a workmanlike manner according to standard practices. Any alteration or deviation from above specifications involving extra costs will be executed only upon written orders, and will become an extra charge over and above the estimate. All agreements contingent upon strikes, accidents or delays beyond our control. Owner to carry fire, tornado and other necessary insurance. Our workers are fully covered by Workmen's Compensation Insurance.  
Authorized Signature:

**ACCEPTANCE OF PROPOSAL: - The above prices specifications and conditions are satisfactory and are hereby accepted. You are authorized to do the work as specified. Payment will be made as outlined above.**

DATE OF ACCEPTANCE: \_\_\_\_\_

SIGNATURE: \_\_\_\_\_

Quote

EZ Glide Garage Doors & Openers  
P. O. Box 3  
1700 E. North Avenue  
Little Chute, WI 54140-0003  
(800)372-3667 (920)788-3561  
(920)788-3564 (fax)

Quote Number: 0054290  
Quote Date: 2/25/2026

Customer Number: 01-M2222  
Telephone #:  
Fax #: 920-751-8150  
miron@mironconst.com

MIRON CONSTRUCTION CO., INC.  
P.O. BOX 509  
NEENAH, WI 54957  
Confirm To:

Job Address:  
GREENLAKE CTY HIGHWAY COMMISSION  
N4843 WI-73  
PRINCETON, WI 54968

Estimator	Quote Expires	F.O.B.	Terms
DAVE S.	3/27/2026		NET 15 DAYS

COILING DOORS

**\*ALTERNATE TO SPEC\***

ONE (1) - 150A 12' X 10' "COOKSON" INSULATED COILING SERVICE DOOR

- FACE MOUNT
- STAINLESS STEEL
- MOTOR OPERATION
  - NEMA 4X MODIFICATION
  - 460/3/60
  - PHOTO EYES
  - 3 BUTTON WALL STATION

ONE (1) - 151A 10' X 12' "COOKSON" INSULATED COILING SERVICE DOOR

- FACE MOUNT
- GALV. STEEL - WHITE
- MOTOR OPERATION
  - 460/3/60
  - PHOTO EYES
  - 3 BUTTON WALL STATION

**\*FORKLIFT ASSISTANCE REQUIRED - SUPPLIED BY OTHERS\***

INSTALLED BY EZ GLIDE... \$38,800.00 NO TAX

**\*ALL ELECTRICAL WORK, LOW-VOLTAGE, WIRING, CONDUIT AND CONNECTIONS BY OTHERS\***

Order Total: 38,800.00

All material is guaranteed to be as specified. All work to be completed in a workmanlike manner according to standard practices. Any alteration or deviation from above specifications involving extra costs will be executed only upon written orders, and will become an extra charge over and above the estimate. All agreements contingent upon strikes, accidents or delays beyond our control. Owner to carry fire, tornado and other necessary insurance. Our workers are fully covered by Workmen's Compensation Insurance.  
Authorized Signature:

ACCEPTANCE OF PROPOSAL: - The above prices specifications and conditions are satisfactory and are hereby accepted.  
You are authorized to do the work as specified. Payment will be made as outlined above.

DATE OF ACCEPTANCE: \_\_\_\_\_

SIGNATURE: \_\_\_\_\_

# THE AMERICAN INSTITUTE OF ARCHITECTS



AIA Document A310

## Bid Bond

Bond No.: 521918

KNOW ALL MEN BY THESE PRESENTS, that we Essential Products Corporation dba EZ Glide Garage Doors

1700 E North Avenue, Little Chute, WI 54140

as Principal, hereinafter call the Principal, and Merchants National Bonding, Inc.

P.O. Box 14498, Des Moines, IA 50306-3498

a corporation duly organized under the laws of the State of Iowa

as Surety, hereinafter called the Surety, are held and firmly bound unto Green Lake County

571 Co Rd A, Green Lake, WI 54941

as Obligee, hereinafter called the Obligee, in the sum of Five Percent of Bid Amount

Dollars (\$ 5 % ),

for the payment of which sum well and truly to be made, the said Principal and the said Surety, bind ourselves, our heirs, executors, administrators, successors and assigns, jointly and severally, firmly by these presents.

WHEREAS, the Principal has submitted a bid for New Highway Facility - Green Lake County Princeton, WI / Bid Package 03 Miron Project# 240830

NOW THEREFORE, if the Obligee shall accept the bid of the Principal and the Principal shall enter into a Contract with the Obligee in accordance with the terms of such bid, and give such bond or bonds as may be specified in the bidding or Contract Documents with good and sufficient surety for the faithful performance of such Contract and for the prompt payment of labor and materials furnished in the prosecution thereof, or in the event of the failure of the Principal to enter such Contract and give such bond or bonds, if the Principal shall pay to the Obligee the difference not to exceed the penalty hereof between the amount specified in said bid and such larger amount for which the Obligee may in good faith contract with another party to perform the Work covered by said bid, then this obligation shall be null and void, otherwise to remain in full force and effect.

Signed and sealed this 10th day of February 2026

Essential Products Corporation dba EZ Glide Garage Doors

*Matt Schrammer*  
(Witness)

*[Signature]*  
(Principal)  
Owner/Proj. Mgr  
(Title)



1-800-372-3667  
1700 E. North Ave.  
Little Chute, WI 54140  
sales@ezglideinc.com

*[Signature]*  
(Witness)

Merchants National Bonding, Inc.

(Surety)  
*[Signature]*  
(Title)  
Bennett DeBouche Attorney-in-Fact

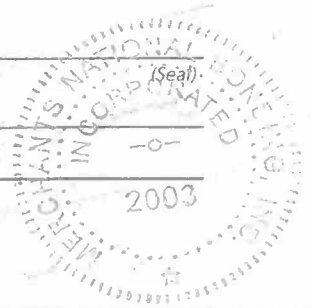

240830 Green Lake Hwy - Potential Cost (PCI) Log

6/4/2026

Miron PCI#	Date Submitted	Status	Reason for Change (Bulletin, RFI, etc.)	Item Description	Contingency	Change Order	Comments	
<b>Potential PCI</b>								
PCI#			RFI#71	Add Moisture Barrier Primer Rms 137, 139, 140 & 141			Hot/cold wall and plank ceiling	
PCI#			Owner	Larger Monument signs at Main Entrance			Initial pricing Provided for review	
PCI#21		Pricing	CB#7	Back Flow Preventer Changes				
<b>Subtotal of Open (Not yet Submitted or Under Review) PCIs</b>					\$ -	\$ -		
<b>PCIs in for Approval</b>								
PCI#17	6/4/26	Submitted	CB#5	Owner Changes in Locker Rooms, RFI and Submittal Updates	\$ 8,519.00			
PCI#18	6/4/26	Submitted	CB#6	PEMB Pier Updates based on PEMB Base Plates	\$ 7,370.76			
''								
<b>Subtotal of Open (Submitted and Under Review) PCIs</b>					\$ 15,889.76	\$ -		
<b>PCIs APPROVED</b>								
PCI#1	2/2/26	Approved	CB#1	Revisions to BP#1 work for Contractors	\$ (203,526.29)			
PCI#2	1/26/26	Approved	BP#2 CO	BP#2 Change Order	\$ 692,499.00	\$ 15,484,119.00		
PCI#3	2/2/26	Approved	CB#2	BP#1 Contractor Changes for Addendum #1 in BP#2			\$19,899.00 BP#1 Additional Scope Allowance	
PCI#4	2/2/26	Approved	Unforseen	Site Balancing			\$106,739.50 out of soils allowance	
PCI#5	2/2/26	Approved	Scope Move	Move Seeding/landscaping to BP#1 Contractor (Addendum #1)	\$ (32,850.00)			
PCI#6	2/2/26	Approved	RFI#8	Lower Foundations per RFI#8 (documented in CB#3 drawings)	\$ (56,108.87)			
PCI#7R1	3/4/26	Approved	CB#3	Misc Structural/HVAC & Electrical	\$ 5,286.50		Original PCI cost was \$5,836.11, revised concrete	
PCI#8.01	3/10/26	Approved	CB#4	Various Updates from DSPS review	\$ 10,073.77		Revised per Excel review Initial Pricing \$11,582.77	
PCI#9	2/23/26	Approved	Owner	Change Controls to ACC - Delta			\$82,925.00 From Design/Estimating Contingency	
PCI#10	2/23/26	Approved	Excel	SS Cleanouts	\$ 8,966.00			
PCI#12	2/23/26	Approved	Alt#7	Eliminate Alternate#7	\$ (55,230.00)		Credit to eliminate	
PCI#15	4/17/26	Approved	Excel/Owner	Delete 55LF of Guardrail - Owner to Complete Work	\$ (4,905.00)		Northeast Asphalt	
PCI#16	4/17/26	Approved	Excel/Owner	Change DEF dispenser to 1000 gal in lieu of 500	\$ 4,100.00			
PCI#19	5/18/26	Approved	Owner	Change Out Existing Operating and Emergency Vents at Fuel Tank	\$ 4,027.64			
PCI#20	5/20/26	Approved	CB#1	Area F Walls with 4' bump wall			\$203,630.57 Allowance	
PCI#22	5/18/26	Approved	Owner	Modern OH 50-50 split	\$ 20,530.00			
<b>Subtotal Approved PCIs</b>					\$ 392,862.75	\$ 15,484,119.00		
<b>Specification Allowance</b>								
					<b>Original Contingent Amount</b>	\$ 644,455.00	\$ 14,535,991.00	<b>Original Contract Value</b>
					<b>Approved PCI Totals</b>	\$ 392,862.75	\$ 15,484,119.00	<b>Approved PCI that are Project Modifications</b>
					<b>Current Remaining Contingency Amount</b>	\$ 1,037,317.75	\$ 30,020,110.00	<b>Current Contract Value</b>
<b>Potential COR Rejected or Canceled</b>								
PCI#			Owner	Change Brick to Ruby Red Velour	\$ 3,000.00		Rejected by Owner \$2,900+ mark-up	
PCI#11	2/23/26	Submitted	Excel	Fiberglass Trench Drain Covers	\$ 17,681.00		It was decided as a team to not proceed	
PCI#			RFI#31	Credit for Square Duct in lieu of Oval	\$ 3,814.00		VOIDED Excel will not proceed	
PCI#			Excel/Owner	SS Door Frames change from 304SS to 316 SS	\$ 10,484.55		VOID Owner will not proceed	