

Green Lake County Drainage Board

571 County Rd. A
Green Lake, WI 54941

Steven Foust - 920-426-3639
David Gneiser - 920-369-6314
Rodney Zietlow - 920-369-8115

Drainage Board Public Hearing Notice

Date: August 2, 2023 Time: 6:00 p.m.
Training Room, Green Lake County Government Center
571 County Rd A, Green Lake WI

AGENDA

Committee Members

Dave Gneiser - Chair
Steven Foust – Vice Chair
Rodney Zietlow - Secretary

1. Call to Order
2. Certification of Open Meeting Law
3. Pledge of Allegiance
4. Approval of Agenda
5. Approval of November 09, 2022 Minutes
6. Public Comment (3 min limit)
7. Public Hearing:

Each item below will consist of:

- Public Comment (3-minute limit)
- Committee Discussion
- Committee Decision/Action

Item 1 – Ditch side slope repair at two locations on Town Drain, First location station 199+00 to 200+00 (100 ft) located on parcel 020-00189-0100 Robert Alf, Karen Niemuth property
Second location station 253+00 to 255+00 (200 ft) located on Parcel 020-00089-0000 John Schrock property

Item 2 – Culvert replacements at station 309+94 located on Parcel 034-03334-0000 Rodney Zietlow, Karen Zietlow property
And station 335+12 located on parcel 034-03332-0000 Robert Nigbor, Charlotte Nigbor property

Item 3 – Removal of downed trees in Town Drain located at Station 41+00 to 42+00, parcel 020-00231-0000 Scot Harenburg Property

Item 4 – Purchase herbicide to treat brush and trees growing Alongside the town drain and in district corridor.

Item 5 – Set 2024 Seneca-Warren District Assessment.
Discussion and Action on Budget items and Assessment Order

8. Correspondence
9. Committee Discussion
 - Future Meeting Date
 - Future Agenda Items for Action & Discussion
10. Adjourn

Kindly arrange to be present, if unable to do so, please notify the Land Conservation office at 920-294-4051.

Sincerely,
Drainage Board

Green Lake County *Drainage Board*

571 County Rd. A
Green Lake, WI 54941-3188

Steven Foust - 920-426-3639
David Gneiser - 920-369-6314
Richard M Sobieski - 920-229-5285

**Drainage Board
November 9, 2022
6:00 P.M. – 6:52 P.M.
Training Room, Green Lake County Government Center
571 County Rd. A, Green Lake, WI 54941**

Call to Order: The meeting of the Drainage Board was called to order by Chairman Gneiser. The requirements of the open meeting law were certified as being met.

Present: David Gneiser
Steven Foust
Richard M Sobieski

Also Present: Rodney Zietlow, LeRoy Petit, Heidi Weishaar – Green Lake County Land Conservation Department

Agenda: *Motion/second (Sobieski/Foust)* to approve the agenda as presented. Motion carried.

Minutes: *Motion/second (Sobieski/Foust)* to approve the May 4, 2022 meeting minutes as presented. Motion carried.

Public Comments:

Zietlow commented that he would like the bottom of the Seneca-Warren District drain cleaned from South Road to the north into Waushara County. He also stated that the district culvert on his property should have been lowered with last cleaning and it wasn't and he feels that it should be lowered to design specifications if maintenance work will be taking place on the ditch. Zietlow also was wondering if parcel 034-03314-0000 was included in the district. In the original boundary of the district this parcel was included but the board made a motion that it would not be assessed. Zietlow just wanted to make sure that he was not being assessed on this parcel. Board would like Morris to check on this. Zietlow also wondered why some parcels were withdrawn from the district when these parcels were in the original district boundary. He feels that they should be in the district and would petition to bring them back in if needed. Foust stated that the parcels in question are in Managed Forest Law (MFL) and that even if in the district they cannot be taxed for an assessment. Sobieski stated that the board must follow Chapter 88 and ATCP 48. Zietlow restated that he feels the Seneca-Warren ditch needs to be cleaned, he depends on it for cropping. Gneiser stated that metal culvert in town drain at Zietlow's property is the responsibility of the board if it needs to be lowered or replaced. Sobieski feels that the culvert at Zietlow property should be lowered to meet design specs and that a flat bottom culvert should be for replacement. Sobieski had spoke with Petraszak Excavating and they could do the cleaning of the ditch. The plan would be to dig out bottom of ditch to design specs, place the spoil along side the ditch and let it dry for the winter, and then come back in spring and spread the spoils. Board would like Morris to put a cleanout plan together. Foust stated that the original design specs called for a 6 foot bottom on the ditch in the section that is proposed to be cleaned.

Petit wondered what the District 5 assessment was for? Sobieski explained that when the board was looking at working on the district tile they has an estimate of \$25,000 and only had \$1500 in the District 5 account, so the board approved a \$5000 assessment for any repair work on the district tile. Petit was concerned that he was the only one assessed. Sobieski stated that everyone in District 5 was assessed.

Board reviewed drone video from of Seneca-Warren District from Hwy D east to where private lateral from Zietlow property meets town drain. There are concerns that with the high winds we have been having that some of the trees on the ditch bank have fallen into the town drain causing obstructions.

Appearances: none

Report on Annual Inspections:

Board members reviewed reports, see attached reports:

District 1 – Gneiser spoke with Steve Smits landowner in district and he would like the ditch cleaned and brush removed.

District 2 – Foust stated that ditch is in good shape and no maintenance is needed.

District 3 – Foust stated that ditch is in good shape and no maintenance is needed.

District 4 - Morris spoke with Mashuda, only landowner in district, and they will be filing a petition to dissolve their district. Mashuda’s are aware that any outstanding debt must be paid for this to happen.

District 5 – Sobieski reported that ditch looked good. With town rerouting some ditch water out of the district the Stanish Disterhaft property no longer drains into District 5. Disterhaft will have to petition the board to be withdrawn from the district.

Seneca-Warren District – Sobieski reported the brush needs to be cut and bottom of ditch needs to be cleaned from approximately South Rd to 26th Ct.

Review and Approve DATCP Report:

Motion/second (Sobieski/Foust) to approve the DATCP reports as presented. Motion carried.

Discussion/Action on Maintenance Issues in All Districts:

Discussion held on cleaning of Seneca-Warren District.

Motion/second (Foust/Sobieski) to clean the Seneca-Warren ditch. Motion carried.

Motion/second (Sobieski/Foust) to replace and lower culverts in Seneca-Warren District drain where indicated in original plan profile. Discussion by Foust that he would like to use HDPE pipe, Sobieski not sure if HDPE will work. Motion carried.

Invoice: Motion/second (Sobieski/Foust) to approve \$309.00 invoice to

Berlin Journal Newspapers for Class II Notice. Motion carried

Correspondence: none

Committee Discussion: Board would like Morris to contact Diggers Hotline for locate at South Rd.

Future Meeting Date: None set at this time

Future Agenda Items for Action & Discussion:

Adjourn: Motion/second (Sobieski/Foust) to adjourn. Motion carried.

Respectfully submitted, Todd Morris, Recorder

Meeting expenses: Ditch #1	<u>1%</u>	Ditch #5	<u>1%</u>
Ditch #2	<u>1%</u>	Seneca-Warren	<u>95%</u>
Ditch #3	<u>1%</u>	General	<u> </u>
Ditch #4	<u>1%</u>		



Schrock bank failure, view looking south



Schrock bank failure, view looking north



Schrock bank failure, filling in channel



Schrock bank failure, view looking north



Downed Trees in Ditch and Dead on south bank, view looking east



Downed Trees, view looking east

SENECA WARREN DRAINAGE DISTRICT

GREEN LAKE COUNTY, WISCONSIN

TOWNSHIP OF BERLIN T.17N.-R.13.E
SECTION 7

TOWNSHIP OF SENECA T.17N.-R.12E.
SECTIONS 1,3,4,9,10,11,12,14,15,16



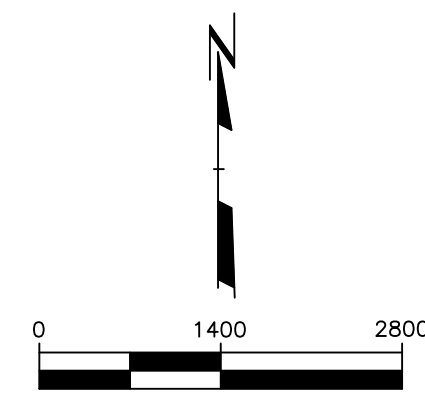
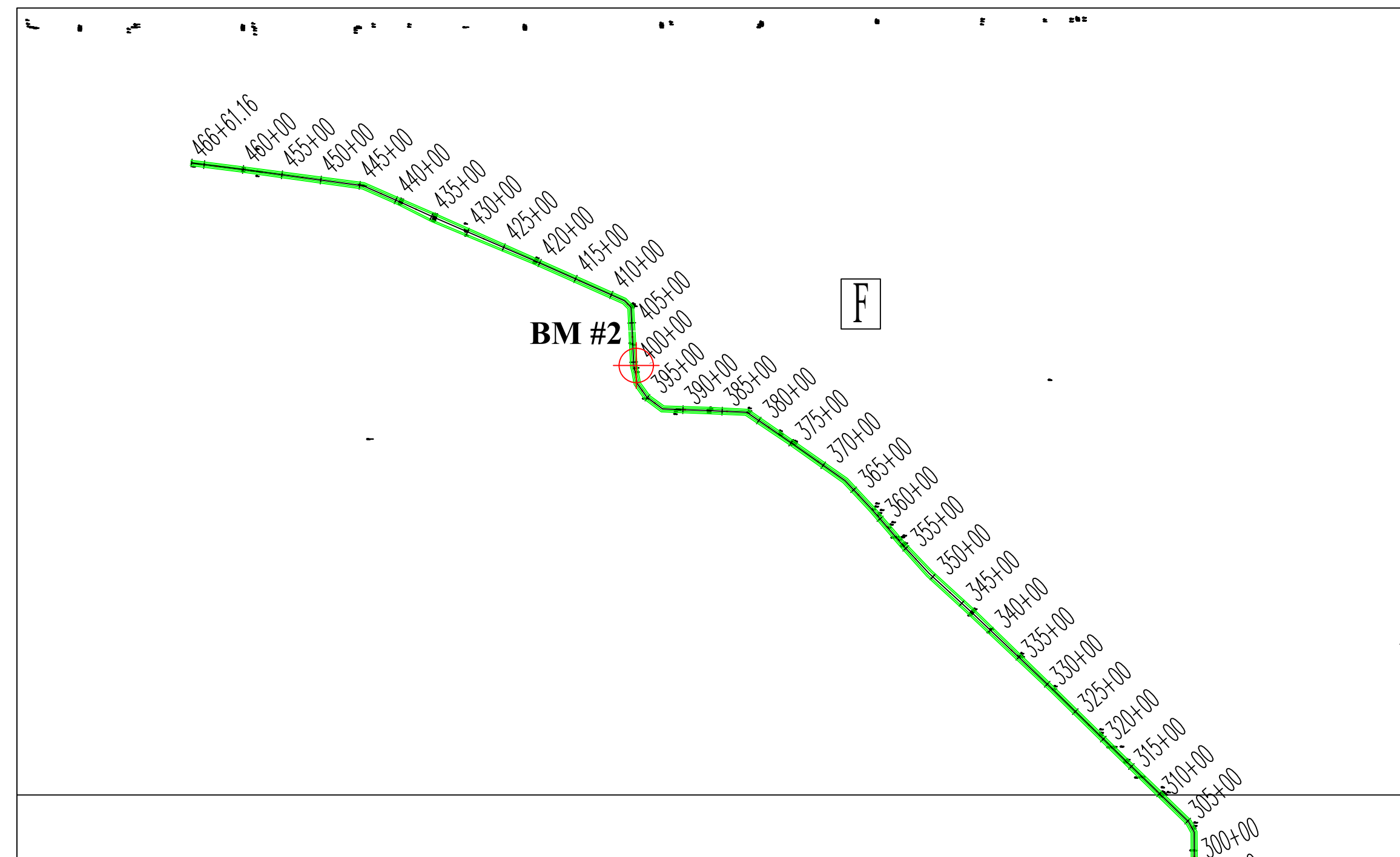
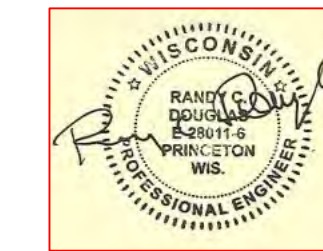

WAUSHARA COUNTY, WISCONSIN

TOWNSHIP OF WARREN T.18N.-R.12E.
SECTIONS 29,30,32,33

TOWNSHIP OF MARION T.18N.-R.11E.
SECTION 25



LEGEND

-  DISTRICT DRAIN & CORRIDOR
-  PRIVATE DRAIN, NATURAL STREAM
-  DISTRICT BOUNDARY
-  BENCHMARK

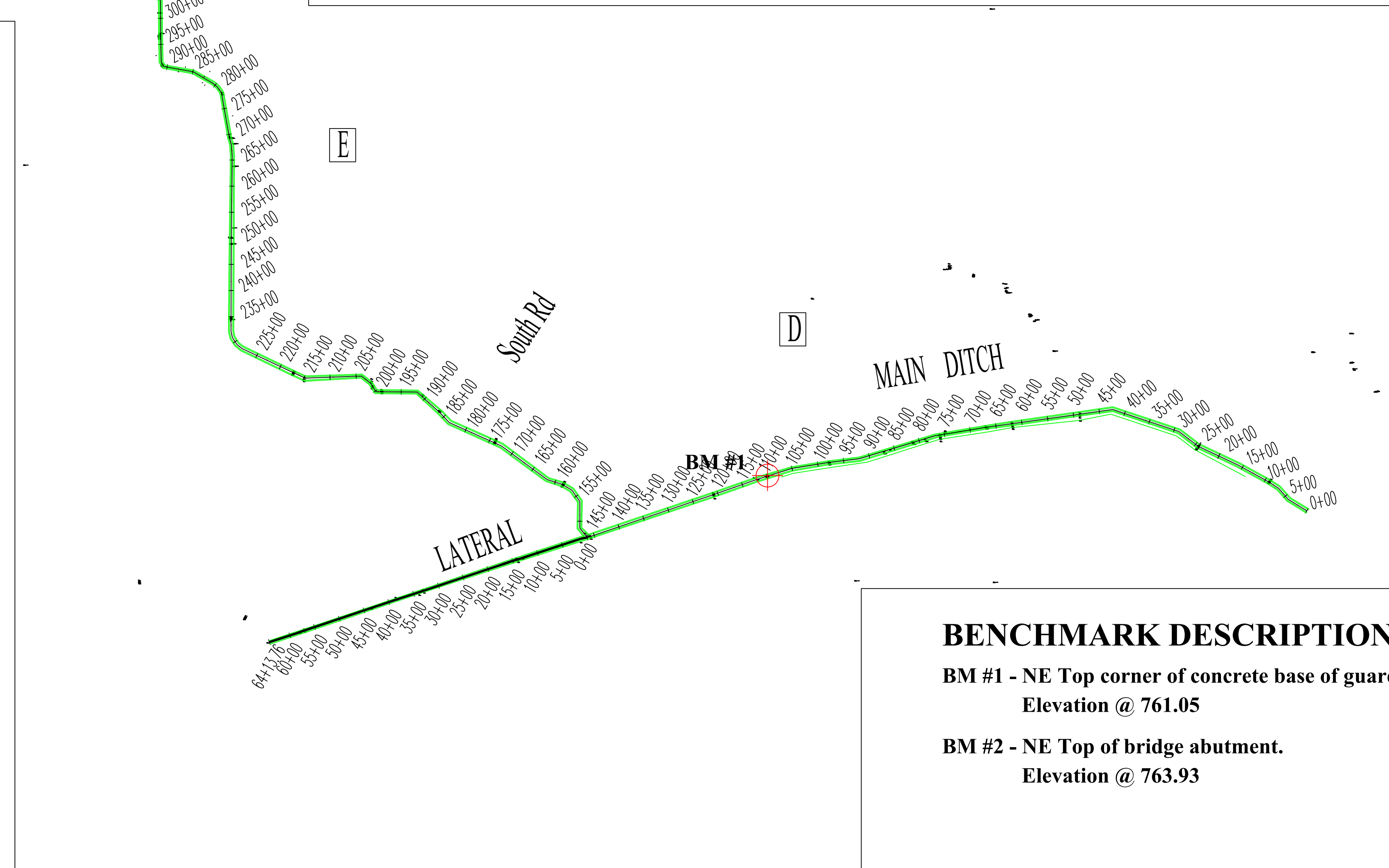

BENCHMARK DESCRIPTIONS:

BM #1 - NE Top corner of concrete base of guard rail.
Elevation @ 761.05

BM #2 - NE Top of bridge abutment.
Elevation @ 763.93

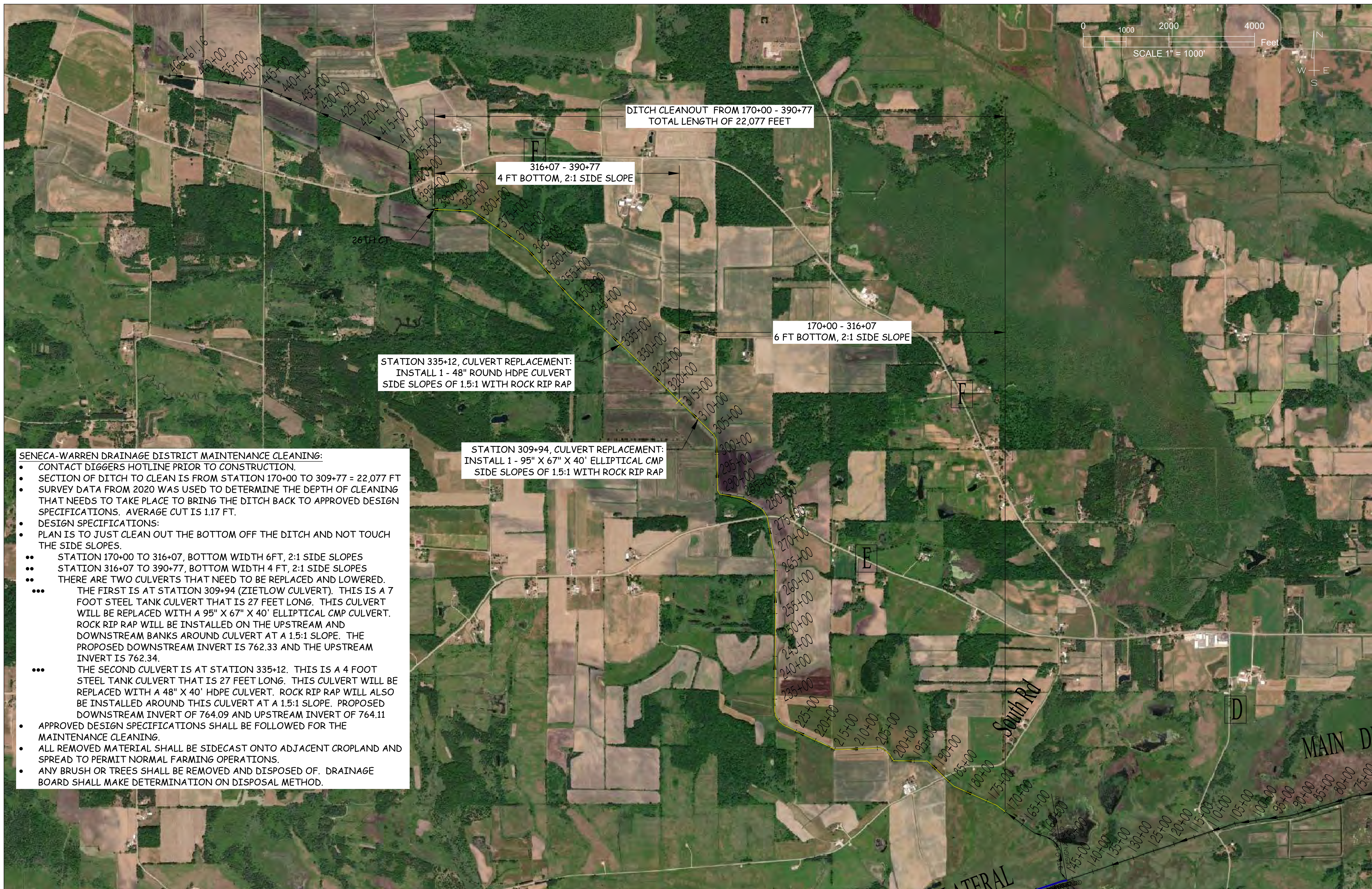

SENECA-WARREN DRAINAGE DISTRICT MAINTENANCE CLEANING:

- CONTACT DIGGERS HOTLINE PRIOR TO CONSTRUCTION.
- SECTION OF DITCH TO CLEAN IS FROM STATION 170+00 TO 309+77 = 22,077 FT
- SURVEY DATA FROM 2020 WAS USED TO DETERMINE THE DEPTH OF CLEANING THAT NEEDS TO TAKE PLACE TO BRING THE DITCH BACK TO APPROVED DESIGN SPECIFICATIONS. AVERAGE CUT IS 1.17 FT.
- DESIGN SPECIFICATIONS:
- PLAN IS TO JUST CLEAN OUT THE BOTTOM OFF THE DITCH AND NOT TOUCH THE SIDE SLOPES.
- STATION 170+00 TO 316+07, BOTTOM WIDTH 6FT, 2:1 SIDE SLOPES
- STATION 316+07 TO 390+77, BOTTOM WIDTH 4 FT, 2:1 SIDE SLOPES
- THERE ARE TWO CULVERTS THAT NEED TO BE REPLACED AND LOWERED.
- THE FIRST IS AT STATION 309+94 (ZIETLOW CULVERT). THIS IS A 7 FOOT STEEL TANK CULVERT THAT IS 27 FEET LONG. THIS CULVERT WILL BE REPLACED WITH A 95" X 67" X 40' ELLIPTICAL CMP CULVERT. ROCK RIP RAP WILL BE INSTALLED ON THE UPSTREAM AND DOWNSTREAM BANKS AROUND CULVERT AT A 1.5:1 SLOPE. THE PROPOSED DOWNSTREAM INVERT IS 762.33 AND THE UPSTREAM INVERT IS 762.34.
- THE SECOND CULVERT IS AT STATION 335+12. THIS IS A 4 FOOT STEEL TANK CULVERT THAT IS 27 FEET LONG. THIS CULVERT WILL BE REPLACED WITH A 48" X 40' HDPE CULVERT. ROCK RIP RAP WILL ALSO BE INSTALLED AROUND THIS CULVERT AT A 1.5:1 SLOPE. PROPOSED DOWNSTREAM INVERT OF 764.09 AND UPSTREAM INVERT OF 764.11
- APPROVED DESIGN SPECIFICATIONS SHALL BE FOLLOWED FOR THE MAINTENANCE CLEANING.
- ALL REMOVED MATERIAL SHALL BE SIDECAST ONTO ADJACENT CROPLAND AND SPREAD TO PERMIT NORMAL FARMING OPERATIONS.
- ANY BRUSH OR TREES SHALL BE REMOVED AND DISPOSED OF. DRAINAGE BOARD SHALL MAKE DETERMINATION ON DISPOSAL METHOD.

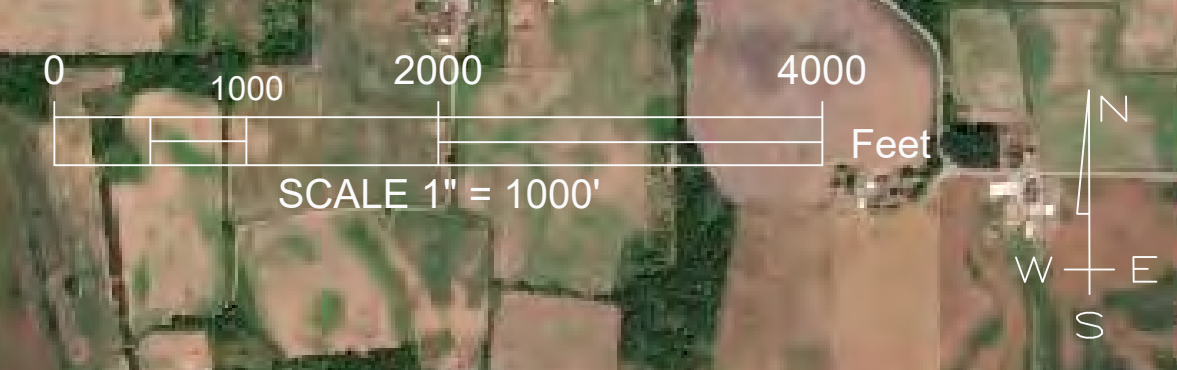

DESIGNED BY: T. MORRIS, P.E.
 DRAWN BY:
 CHECKED BY:
 APPROVED BY:

SENECA-WARREN DRAINAGE DISTRICT
 PLAN VIEW - MAINTENANCE CLEANING

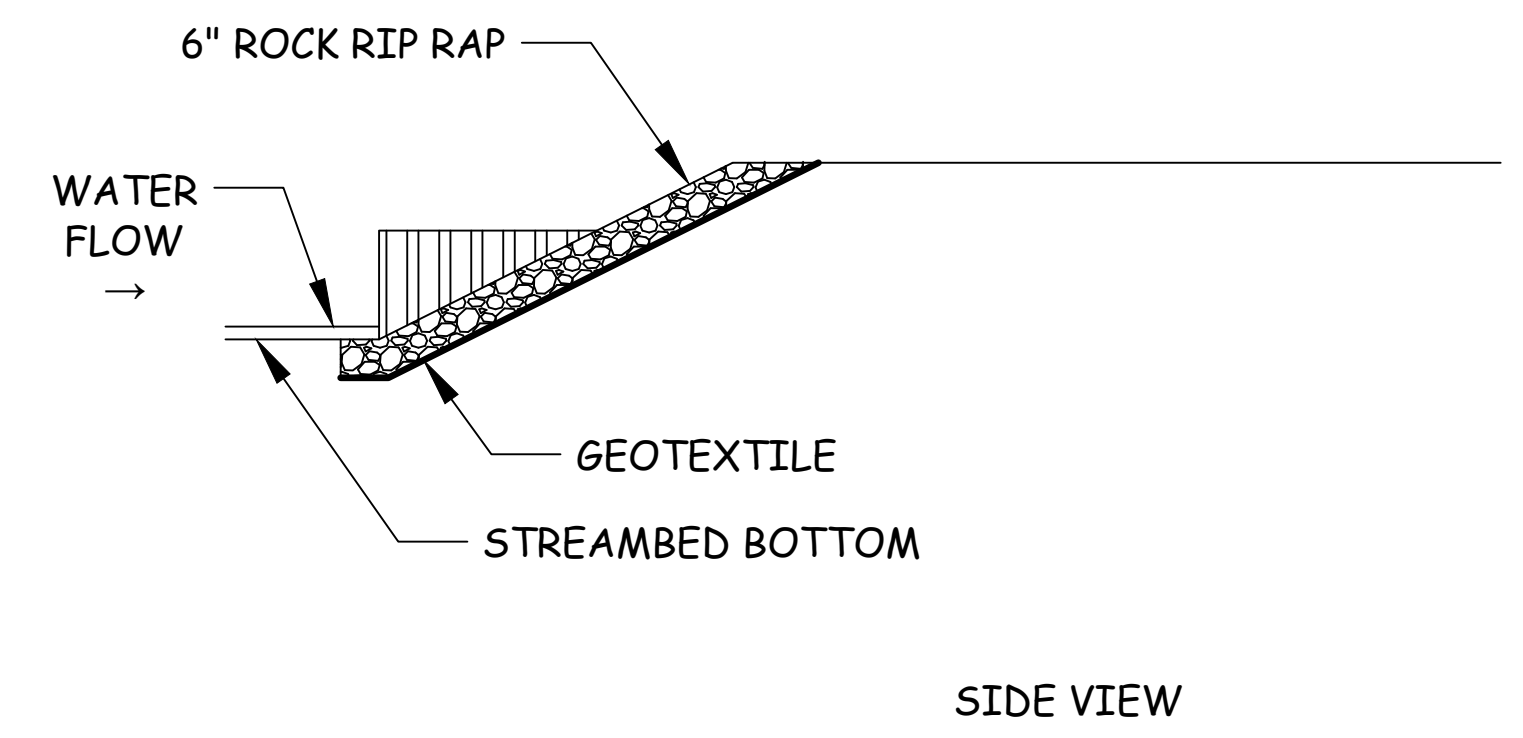
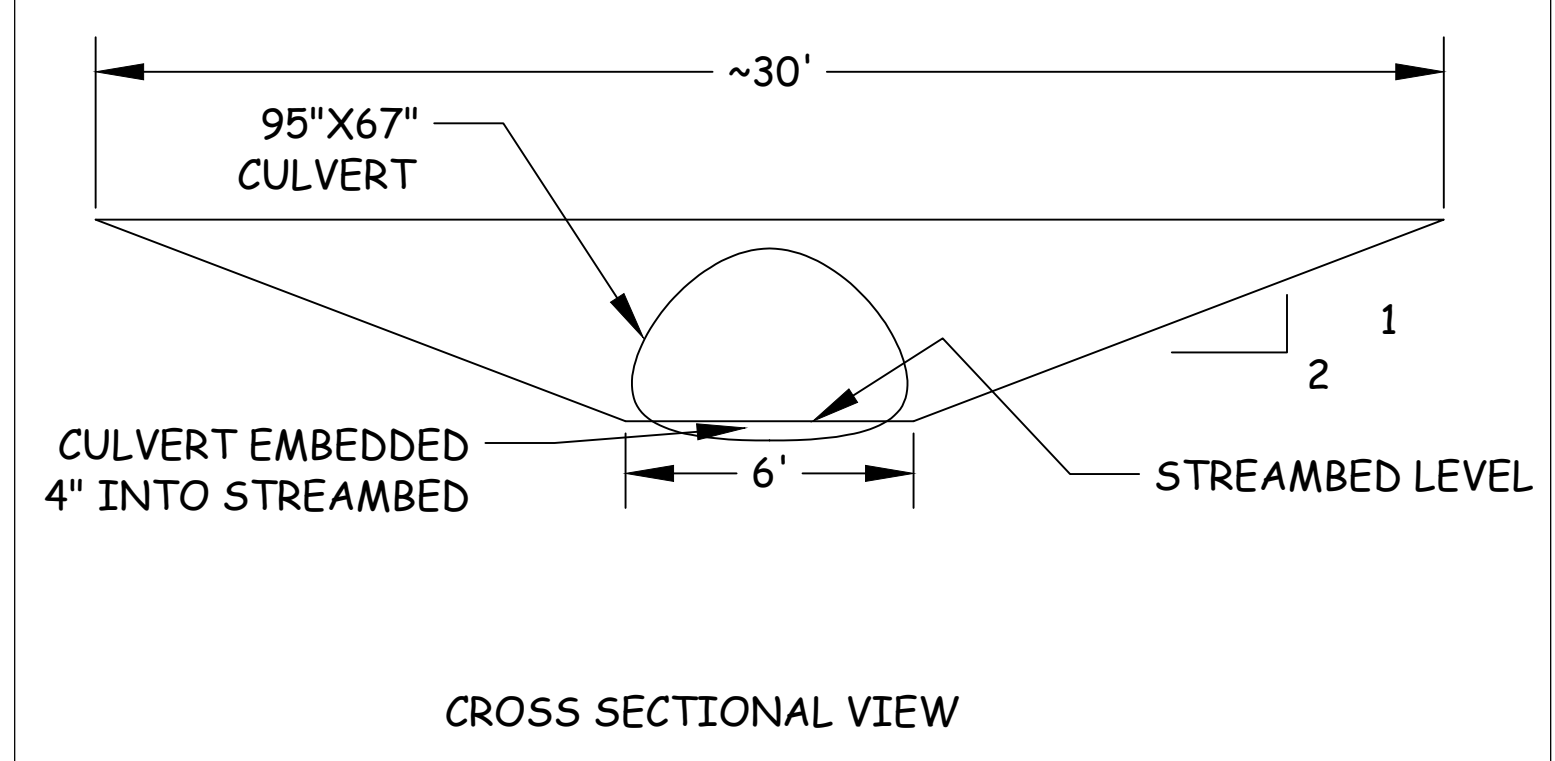
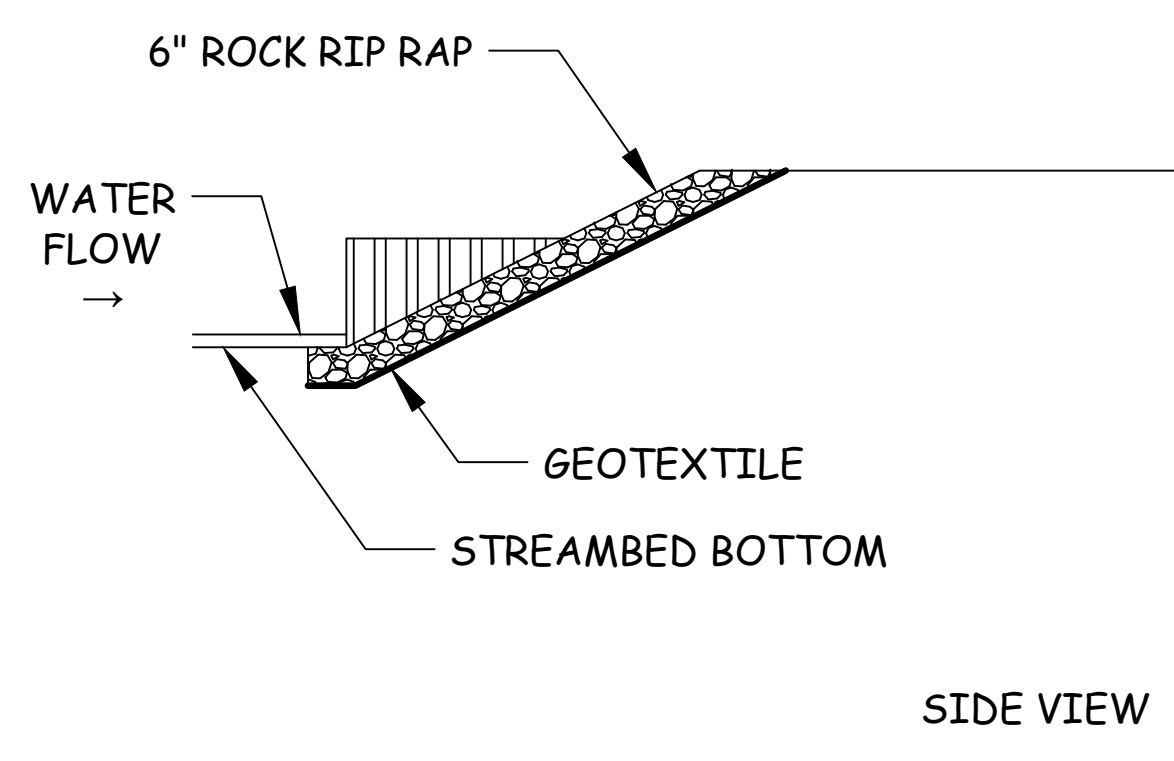
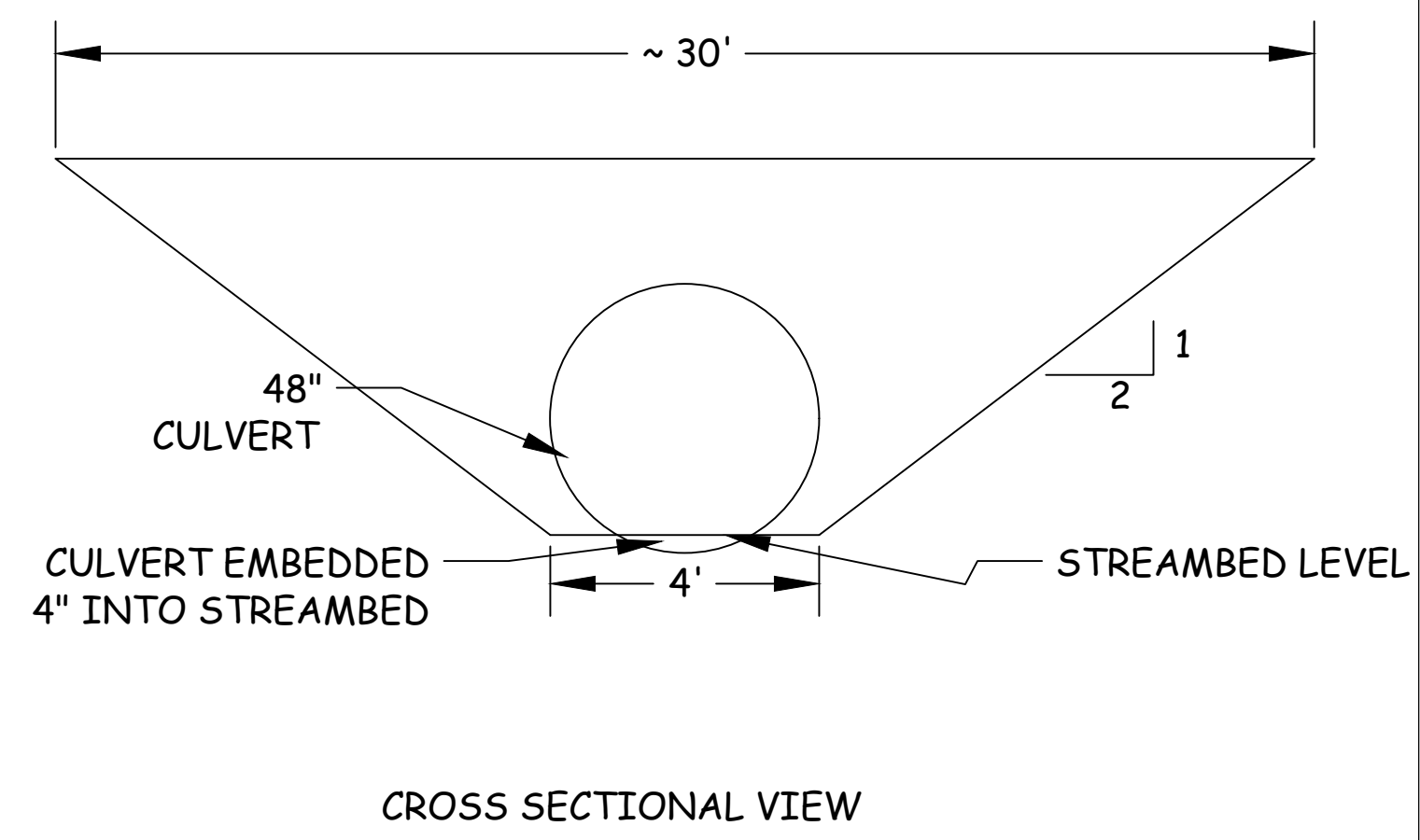
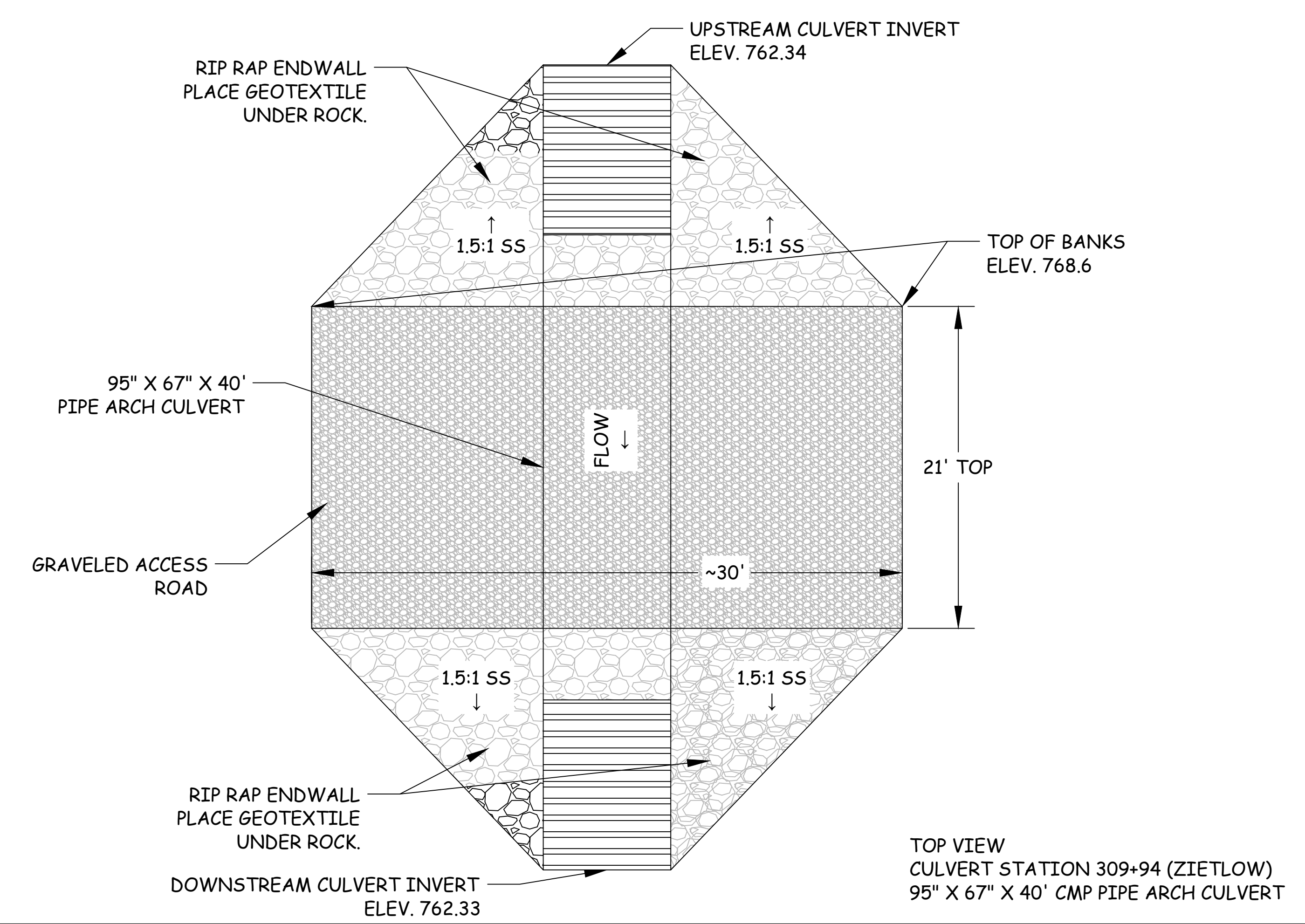
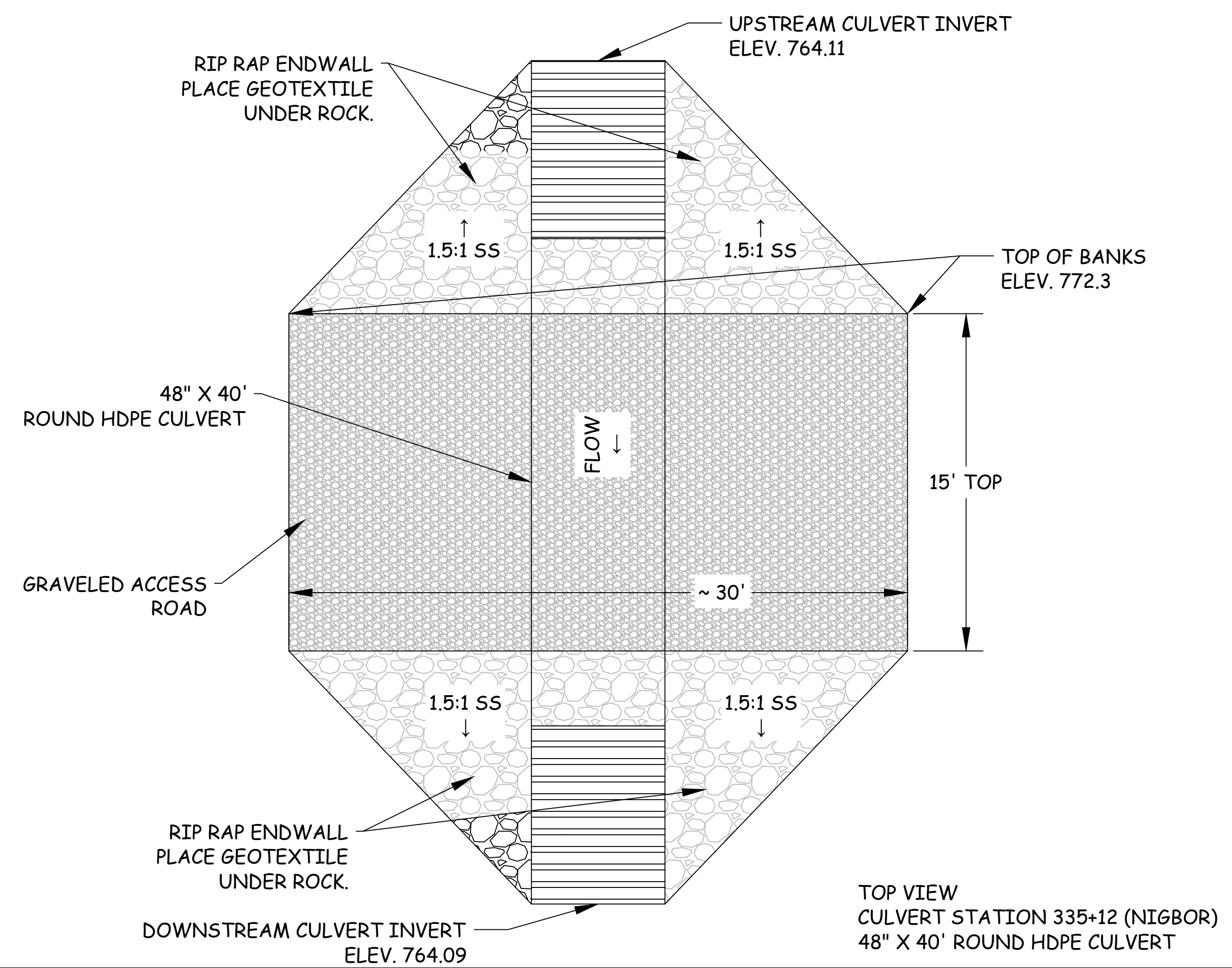

DRAWING NOT TO SCALE

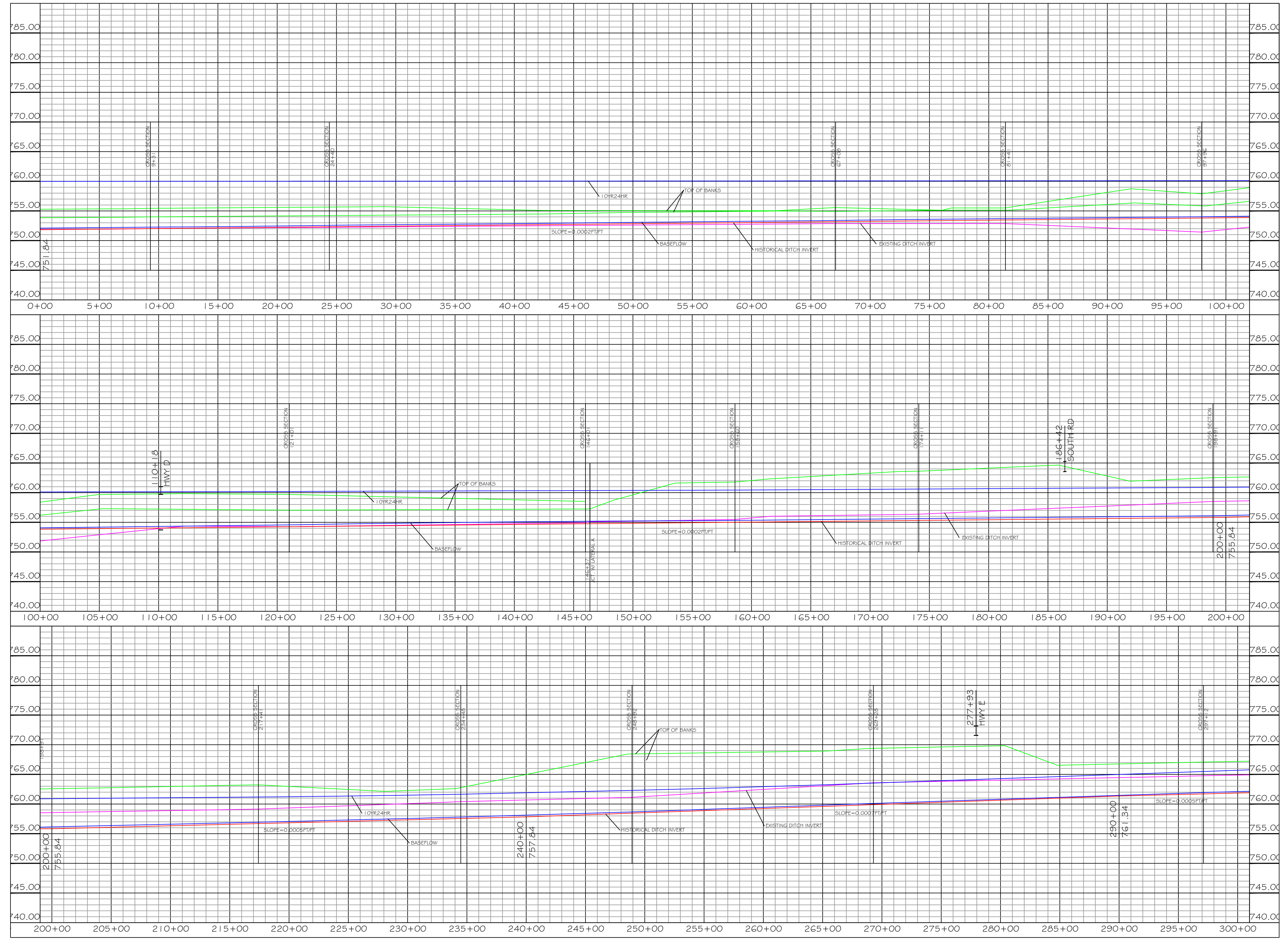

REVISIONS:

Resource Engineering Associates, Inc.
 8505 University Green
 Suite 200
 Middleton, Wisconsin 53562-2507
 P: 608-831-6563 F: 608-831-6564



SENECA WARREN DRAINAGE DISTRICT
 GREEN LAKE COUNTY, WISCONSIN
 MAIN DITCH
 PROFILE

Date: OCT. 2001
 Drawn: DW
 Checked: LB
 Approved: LB

PROFILE1.DWG

000050.1

MAIN DITCH

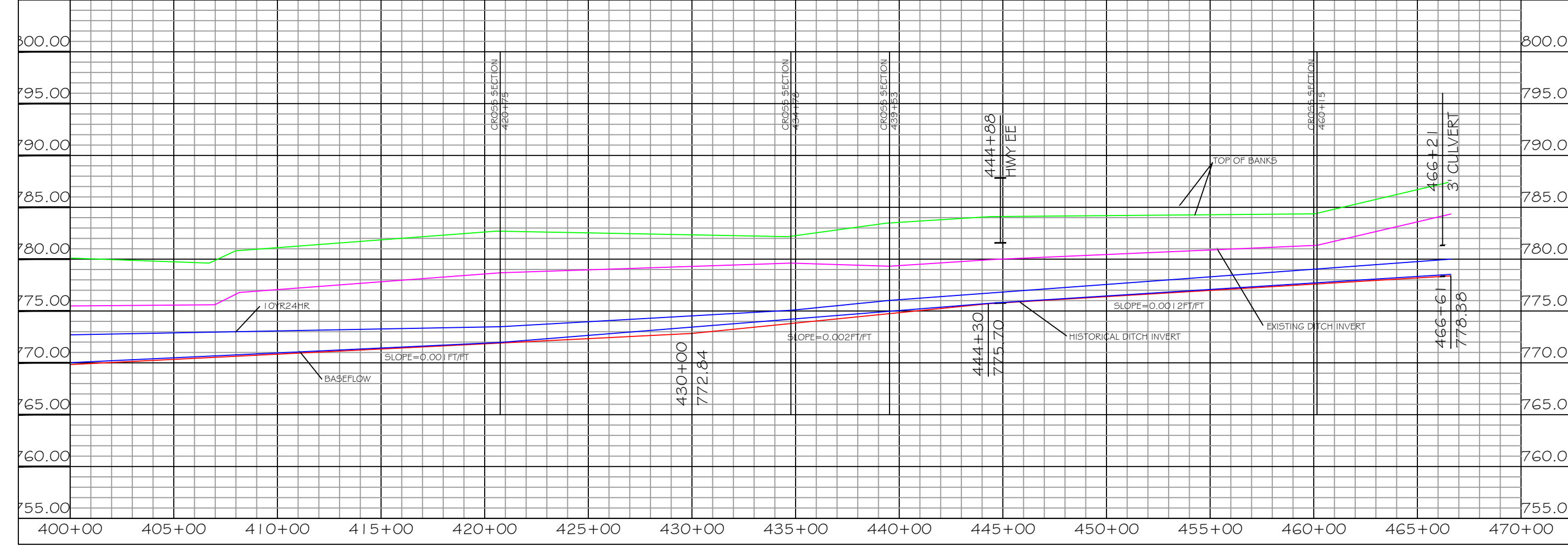
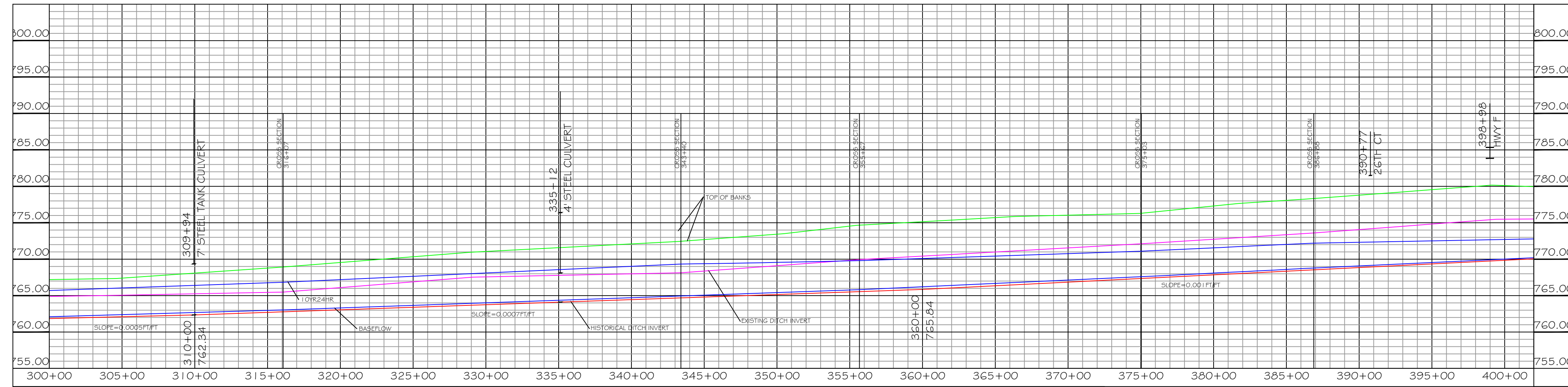

LATERAL A

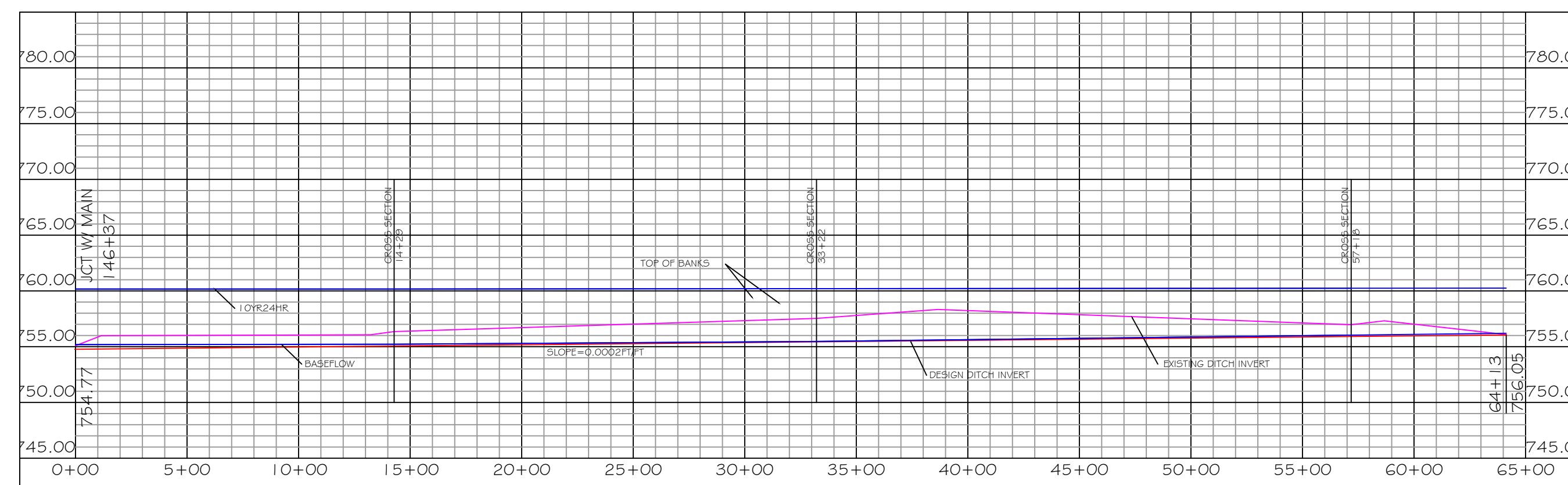

REVISIONS:

Resource Engineering Associates, Inc.
8505 University Green
Suite 200
Middleton, Wisconsin 53562-2507
P: 608-831-6563 F: 608-831-6564



SENECA WARREN DRAINAGE DISTRICT
GREEN LAKE COUNTY, WISCONSIN
MAIN DITCH & LATERAL A
PROFILE

Date: OCT. 2001
Drawn: DW
Checked: LB
Approved: LB

PROFILE2.DWG

000050.1

SHEET 6 OF 11

REVISIONS:

Resource Engineering Associates, Inc.
8505 University Green
Suite 200
Middleton, Wisconsin 53562-2507
P: 608-831-6563 F: 608-831-6564



SENECA WARREN DRAINAGE DISTRICT
GREEN LAKE COUNTY, WISCONSIN
MAIN DITCH
STRUCTURES

Date: OCT. 2001
Drawn: DW
Checked: LB
Approved: LB

SWSTR2.DWG

000050.1

SHEET 11 OF 11

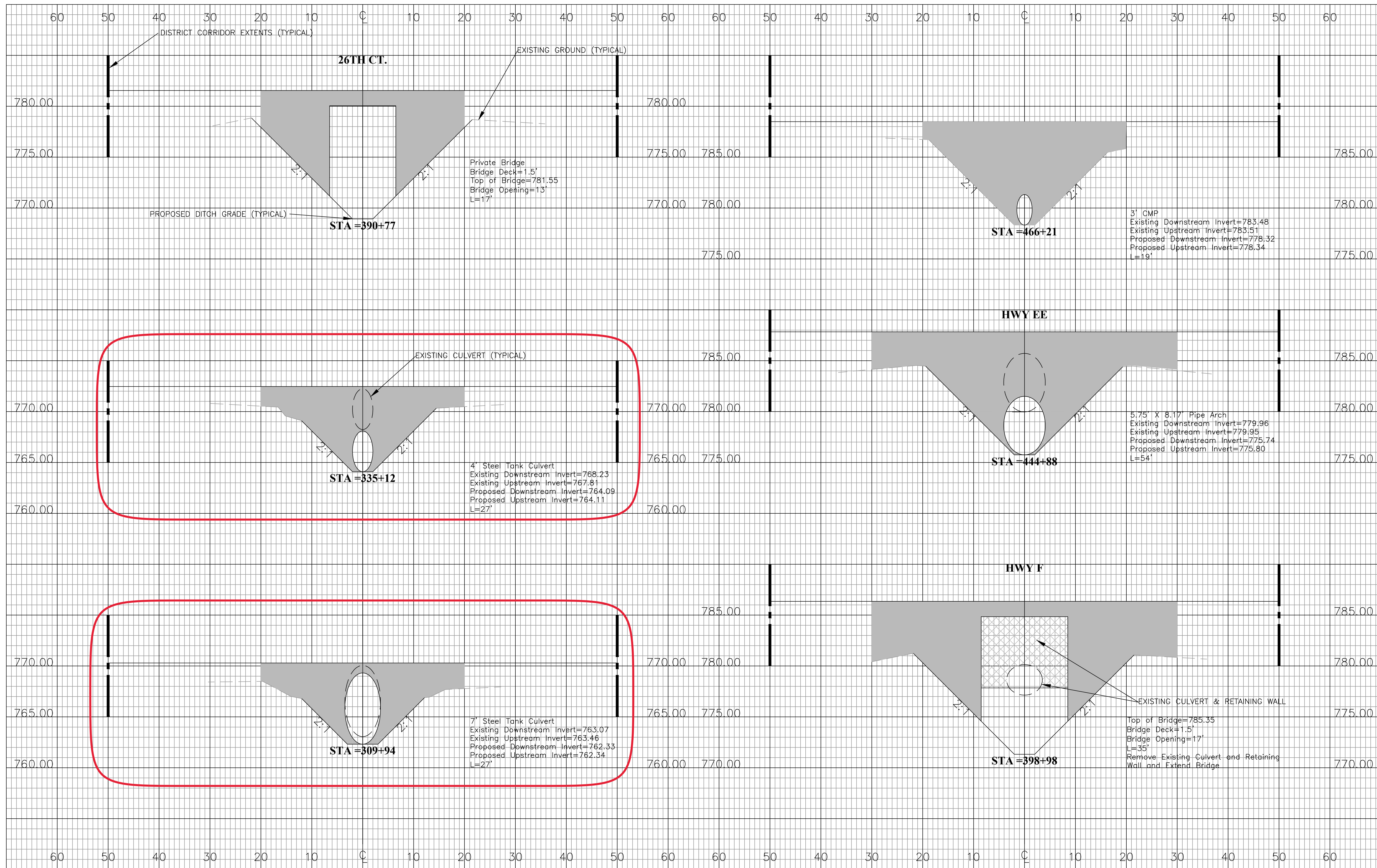

GREEN LAKE COUNTY DRAINAGE BOARD. SENECA-WARREN 2024 BUDGET (SEPT. 1, 2023 - AUGUST 31, 2024)

	----- 8/31/2021 -----	----- 8/31/2022 -----	----- ACTUAL 6/31/2023 -----	----- 2024 PROPOSED -----	----- 2025 PROPOSED -----
DRAINAGE BOARD - DISBURSEMENTS					
PER DIEM/MEETING EXPENSES	-	-	-	600	
LCD/TREASURER REIMBURSEMENT	1,239	1,099	893	3,000	
PUBLIC MEETING NOTICE	63	457	52	400	
LEGAL SERVICES	-	-			
LOAN PRINCIPAL	-	-			
LOAN INTEREST	-	-		-	
WADD DUES	-	-			
FILING FEES WITH REG. OF DEEDS	-	104		120	
ENGINEERING RESOURCES	-	-	-	1,500	
DITCH MAINTENANCE - CLEAN BOTTOM	-		19,859		
DISTRICT 5 REIMBURSEMENTS	-			1,732	
DITCH MAINTENANCE - SIDE SLOPE REPAIR	-			6,000	
DITCH MAINTENANCE - CULVERT REPLACEMENT				25,000	
DITCH MAINTENANCE - TREE REMOVAL				5,000	
DITCH MAINTENANCE - HERBICIDE				300	
TOTAL EXPENDITURES	-	1,302	1,659	20,804	43,652
<hr/>					
DRAINAGE BOARD - RECEIPTS					
	----- 8/31/2021 -----	----- 8/31/2022 -----	----- ACTUAL 6/31/2023 -----	----- 2024 PROPOSED -----	----- 2025 PROPOSED -----
SPECIAL ASSESSMENTS	3,184	23	27	44,000	
CARRYOVER BALANCE	18,912	20,741	19,105	60	
TOTAL REVENUE	22,096	20,764	19,132	44,060	0