



GREEN LAKE COUNTY

571 County Road A, Green Lake, WI 54941

Original Post Date: 11/03/22

***Post Date: 11-07-2022**

The following documents are included in the packet for the Highway Committee on 11/09/22:

- 1) ***Amended** Agenda
- 2) Minutes of 10/12/22
- 3) CTH Rumble Strip Layout
- 4) 8 Year Highway Improvement Plan
- 5) GTA/Reconstruction Totals
- 6) Commissioner's Report



GREEN LAKE COUNTY HIGHWAY DEPARTMENT

Office: 920-294-4060
FAX: 920-294-4066

Highway Committee Meeting Notice

Date November 9, 2022, Time: 3:00 pm

Location: Green Lake County Government Center, County Board Room 571 County Rd A, Green Lake WI

*AMENDED AGENDA

Committee Members

Bill Boutwell
Chuck Buss
Dennis Mulder
Robert Schweder
Charlie Wielgosh

Becky Pence,
Secretary

1. Call to Order
2. Certification of Open Meeting Law
3. Pledge of Allegiance
4. Approval of Minutes 10/12/2022
5. Public Comment (3minute limit)
6. *Appearances
 - Art Cybul, Village of Marquette, CTH H
7. CTH H Rumble Strips
8. CTH EF Project Update
9. *Discuss 2022 Projects Thank You Article
10. *2023 Equipment Purchases
11. Approval of 8 Year Highway Improvement Plan
12. Discuss GTA Funding and Reconstruction Costs
13. Financials
14. Commissioner's Report
15. Future Meeting Date
 - Regular Meeting 12/14/2022
16. Future Agenda items for action & discussion
17. Adjourn

This meeting will be conducted through in person attendance or audio/visual communication. Remote access can be obtained through the following link: Green Lake County Highway is inviting you to a scheduled Microsoft Teams Meeting.

Microsoft Teams meeting

Join on your computer, mobile app or room device

[Click here to join the meeting](#)

Meeting ID: 249 462 738 26

Passcode: w6hAC6

[Download Teams](#) | [Join on the web](#)

Or call in (audio only)

[+1 689-206-9321,662509674#](#) United States, Orlando

Phone Conference ID: 662 509 674#

[Find a local number](#) | [Reset PIN](#)

Kindly arrange to be present, if unable to do so, please notify our office 920-294-4060. Sincerely, Becky Pence

HIGHWAY COMMITTEE MEETING
October 12, 2022

The meeting of the Highway Committee was called to order by Chair Dennis Mulder at 3:00 PM on Wednesday, October 12, 2022 in the County Board Room, Green Lake County Government Center, Green Lake, WI. The meeting was held both in person and via Zoom. The requirements of the open meeting law were certified as being met. The Pledge of Allegiance was recited.

Present: Dennis Mulder
Chuck Buss
Bill Boutwell
Bob Schweder
Charlie Weilgosh

Absent:

Other County Employees Present: Liz Otto, County Clerk; Derek Mashuda, Highway Commissioner; Cathy Schmit, County Administrator; Jason Franke, Highway Superintendent

APPROVAL OF MINUTES 09/14/2022

Motion/second (Schweder/Boutwell) to approve the minutes of the 09/14/2022 meeting with no changes or corrections. Motion carried with no negative vote.

PUBLIC COMMENT – none

APPEARANCES

• **Barry Rogers, Green Lake Greenways – multi use path options**

Barry Rogers of Green Lake Greenways appeared to request support from the Highway Committee for Phase III of the multi use path which would cross Highway 23, come up the east side of CTH A in the right of way, and cross onto Government Center property at the north entrance, then go around to the sidewalk leading to Commercial St. This would be funded by grants and private donations as the other phases have been. Rogers is asking for a resolution of support so that a grant application can be done by February. County Administrator Cathy Schmit will speak with Corporation Counsel to have the resolution drafted and presented at the next meeting.

DRIVEWAY VARIANCE

• **Ethan Schulz, CTH FF, Village of Kingston**

Jason Franke, Highway Superintendent, explained that this a request for a second driveway for farm use. There are no issues with vision or other considerations.

Motion/second (Buss/Schweder) to approve the driveway variance. Discussion held. All ayes. Motion carried.

CTH EF PROJECT UPDATE

Highway Commissioner Derek Mashuda gave an update on the E/F project. Chair Mulder requested that Mashuda formulate a thank you to the residents and other people that provided supplies and use of their property for the project. This will be discussed at the November meeting.

APPROVAL OF 8 YEAR HIGHWAY IMPROVEMENT PLAN

Highway Commissioner Derek Mashuda outlined the county highway projects for the upcoming years. Discussion held. Art Cybul, Village of Marquette President, spoke in regard to repairs on CTH H. Mashuda will present this again next month after reevaluating and possible changes.

2023 BUDGET

Highway Commissioner Derek Mashuda gave an update on the 2023 budget. Fairground improvements have been added along with some administrative changes.

FINANCIALS

Highway Commissioner Derek Mashuda gave an overview of the highway financials.

COMMISSIONER'S REPORT

Highway Commissioner Derek Mashuda provided an update on current and upcoming projects within the department.

COMMITTEE DISCUSSION

Future meeting date: Regular meeting – November 9, 2022 @ 3:00 PM

Future agenda items:

ADJOURNMENT

Chair Mulder adjourned the meeting at 3:48 PM.

Submitted by,

Liz Otto
County Clerk

DRAFT

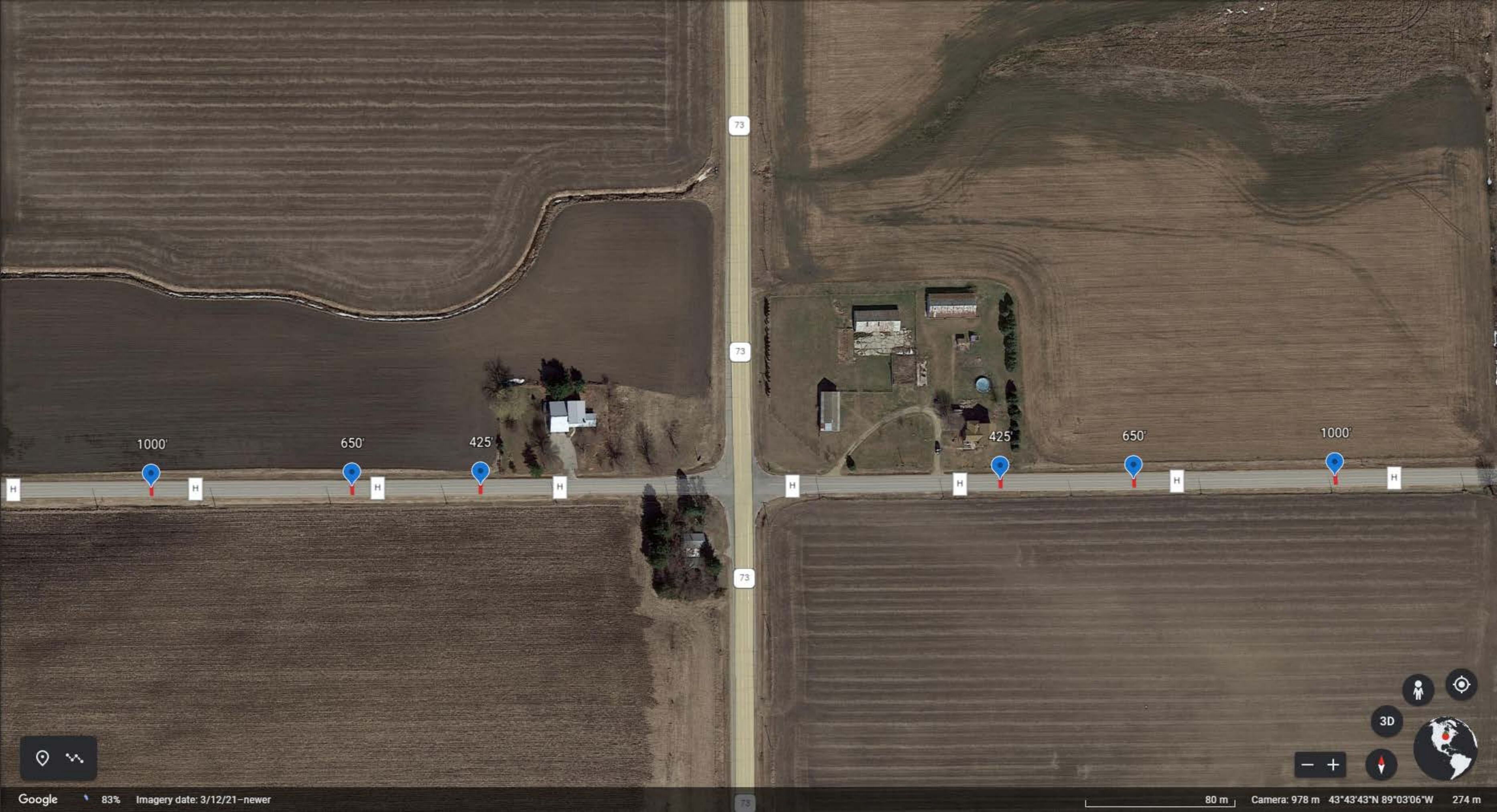

73

73

73

73

1000'

650'

425'

425'

650'

1000'

Map

Satellite



73

73

73

73

H

H

H

H

H

H

H

H



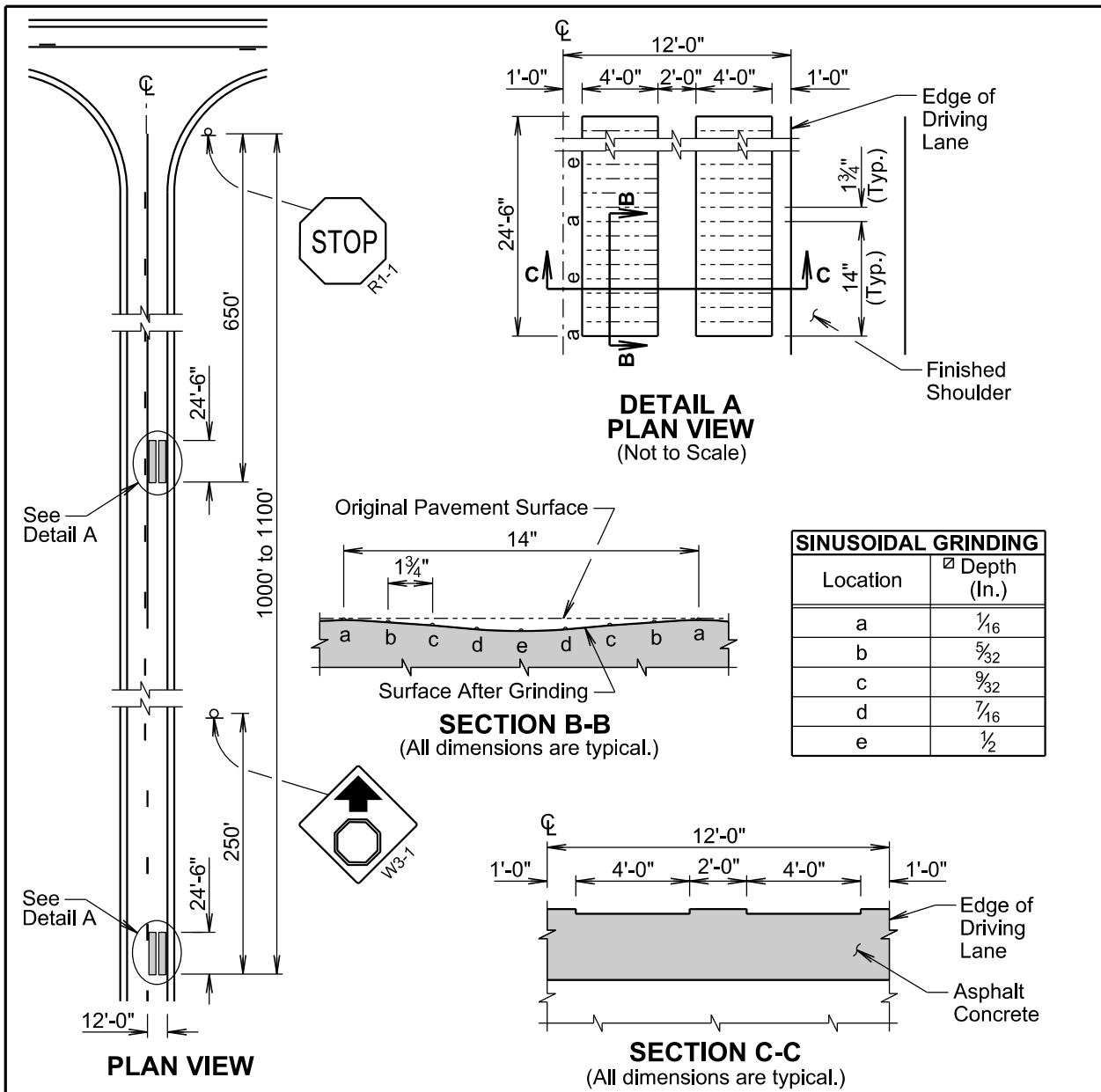

GENERAL NOTES:

Transverse rumble strips will be constructed by grinding continuous sinusoidal indentations in the asphalt concrete pavement as approved by the Engineer. The transverse rumble strips will receive a flush seal or fog seal as specified in the plans.

☐ The sinusoidal transverse rumble strips construction grinding tolerance will be $\pm 1/16$ inch.

Measurement of the sinusoidal transverse rumble strips will be to the nearest square foot. Payment for constructing the sinusoidal transverse rumble strips will be at the contract unit price per square foot for "Grind Sinusoidal Transverse Rumble Strip in Asphalt Concrete Pavement".

January 22, 2021

Published Date: 2nd Qtr. 2022	S D D O T	SINUSOIDAL TRANSVERSE RUMBLE STRIP IN ASPHALT CONCRETE HIGHWAY ADJACENT TO STOP CONTROLLED INTERSECTION	PLATE NUMBER 320.46
			Sheet 1 of 1

6

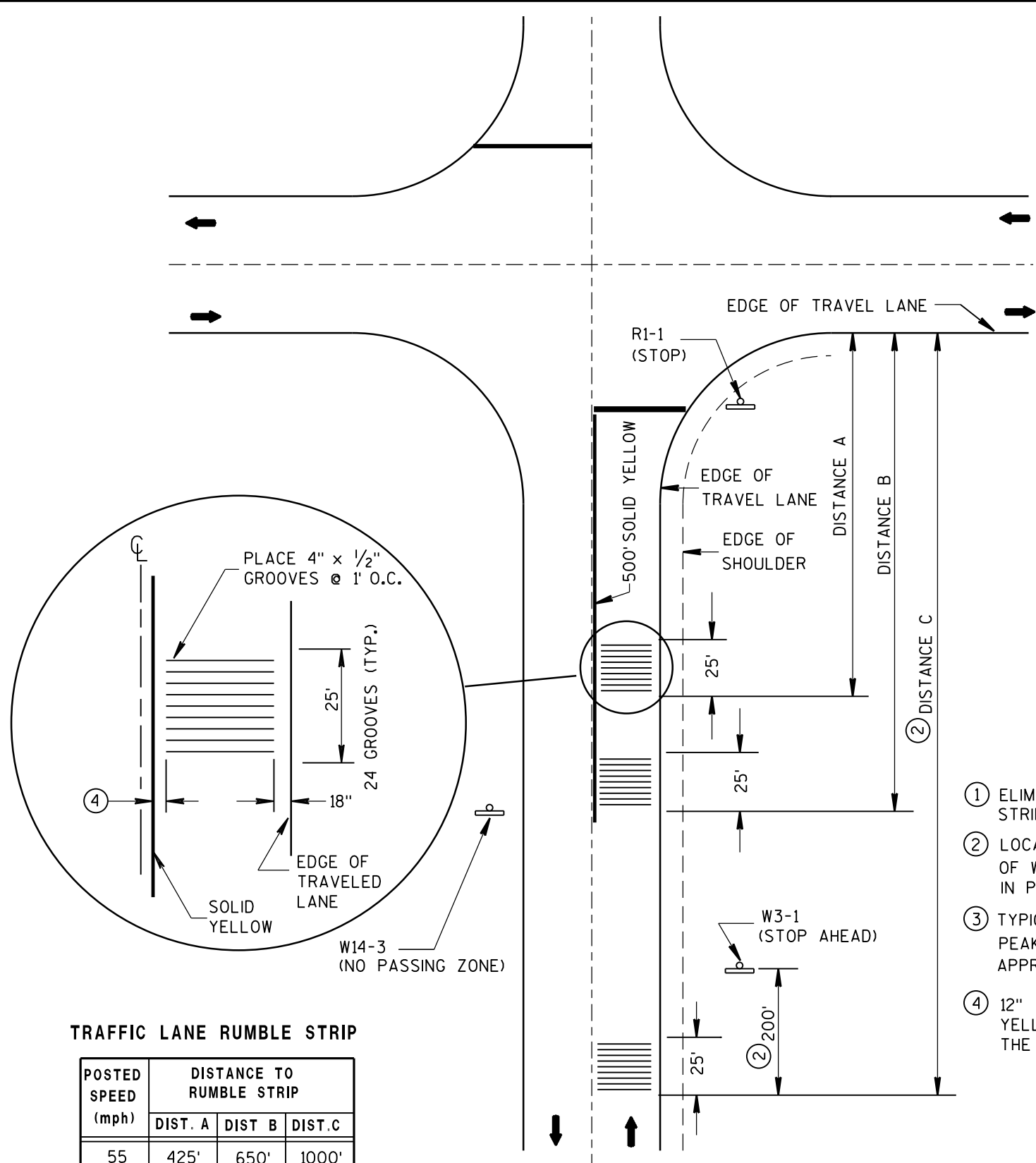

TRAFFIC LANE RUMBLE STRIP

POSTED SPEED (mph)	DISTANCE TO RUMBLE STRIP		
	DIST. A	DIST. B	DIST. C
55	425'	650'	1000'
50	325'	450'	800'
45	275'	400'	650'
40	225'	①	550'
35	175'	①	475'
≤ 30	125'	①	425'

ARROW SYMBOL (➔) SHOWS DIRECTION OF TRAVEL

**PLAN VIEW
RUMBLE STRIP LOCATION**

- ① ELIMINATE THE MIDDLE SET OF RUMBLE STRIPS.
- ② LOCATE RUMBLE STRIP 200' IN ADVANCE OF W3-1 SIGN AS SHOWN. IF W3-1 IS NOT IN PLACE, USE DISTANCE C.
- ③ TYPICAL VERTICAL VARIATION BETWEEN PEAKS AND VALLEYS WITHIN THE CUT APPROXIMATELY 1/16"
- ④ 12" CLEAR BETWEEN THE SOLID YELLOW LINE AND THE EDGE OF THE RUMBLE.

GENERAL NOTES

CONTRACTOR SHALL CONFIRM RUMBLE STRIP LOCATION WITH THE ENGINEER PRIOR TO INSTALLATION. THE ENGINEER MAY MODIFY THE RUMBLE STRIP LOCATION AS FIELD CONDITIONS DICTATE.

WHEN ASPHALTIC PAVEMENT IS NEW IN THE RUMBLE AREA THE CONTRACTOR SHALL ALLOW THE PAVEMENT TO CURE A MINIMUM OF 7 DAYS PRIOR TO RUMBLE INSTALLATION.

PAVEMENT MARKING AND SIGNING DETAILS AND SPECIFICATIONS ARE PROVIDED ELSEWHERE IN THE CONTRACT.

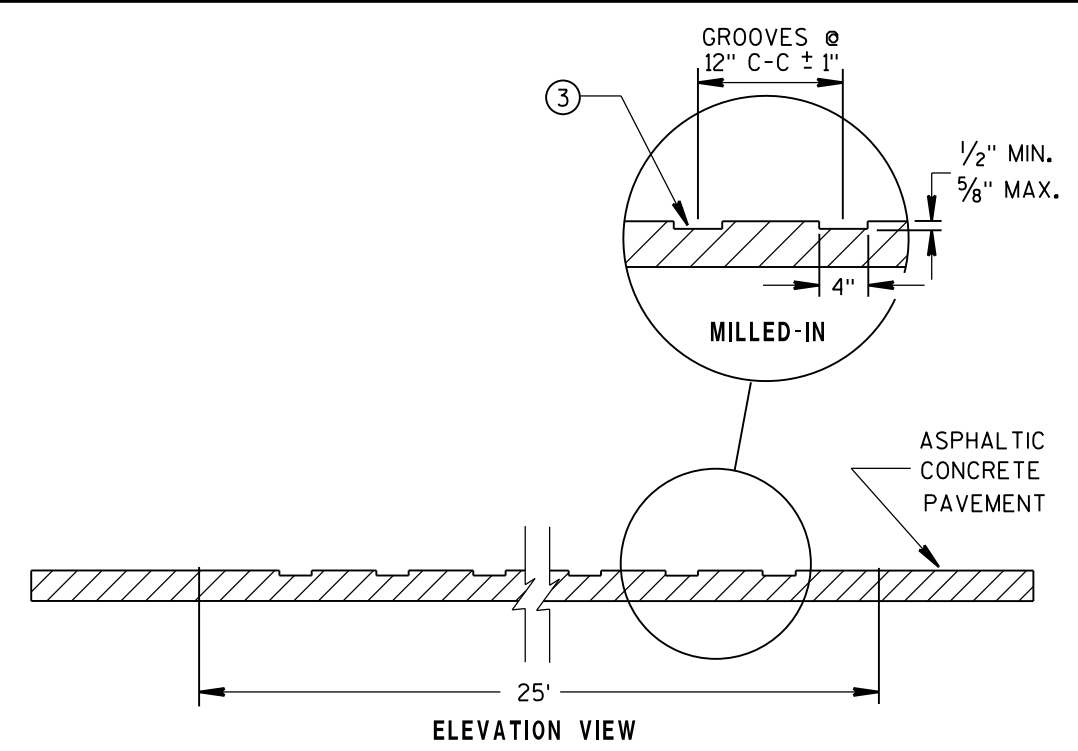

ELEVATION VIEW

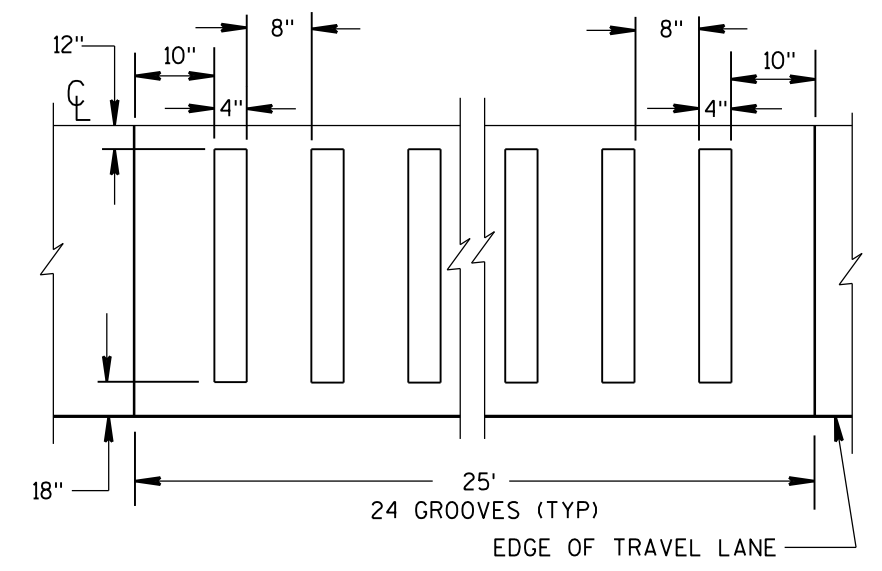

**PLAN VIEW
ASPHALTIC PAVEMENT
MILLED-IN**

6

ASPHALTIC RUMBLE STRIPS AT INTERSECTION	
STATE OF WISCONSIN DEPARTMENT OF TRANSPORTATION	
APPROVED 8-17-2011 DATE	/s/ Jerry H. Zogg ROADWAY STANDARDS DEVELOPMENT ENGINEER
FHWA	



SURFACE PREPARATION TECHNOLOGIES, LLC

Phone: (717) 697-1450

Fax: (717) 697-0813

Corporate Office: PO Box 834, 44 East Main Street, New Kingstown, PA 17072

Branches: Elkhart, IN • Gillette, WY • Belvidere, TN • Conway Springs, KS • Waite Park, MN

DATE: June 9, 2022

BID DATE: June 9, 2022

SPT JOB NO: 2022_2183

SUBJECT: WI Green Lake County

PROJECT NO: Transverse Rumble Strips

LOCATION: CTH H, CTH F

DESCRIPTION	SURFACE	QUANTITY	UNIT PRICE	QUOTE AMOUNT
Transverse Rumble Strips	ASPHALT	3.00 SETS	\$ 1,650.00	\$ 4,950.00
Mobilization	One Only	1 LS	\$ 5,550.00	\$ 5,550.00
TOTAL QUOTE				\$ 10,500.00

CONSTRUCTION TIME: 1 work shift(s) or less

We are pleased to quote on the above listed project. The following inclusions and exclusions apply:

- 1 Valid for one mobilization. Additional mobilizations will be billed at \$5,550.00 each.
- 2 Valid for day work hours only.
- 3 Quote based on a minimum of 8 hours per shift in the number of work shifts listed above.
- 4 Quote based on advertised completion date. Pricing for extended or accelerated completion dates require SPT approval.
- 5 Any retainage to be withheld shall be equal to retainage withheld by the owner.
- 6 This quote to become the prevailing part of the subcontract.
- 7 SPT will honor this quotation for 30 days after bid date.
- 8 Excludes excise tax, gross receipts tax, railroad insurance, and general contractor association dues.
- 9 Excludes TERO taxes, fees, licenses or hiring, if required.
- 10 Excludes bond cost. If requested, a bond will be provided at an additional cost of 1.5% with a \$100 minimum.
- 11 Structures that interfere with installation of rumble strips will be remedied at General Contractor's expense.
- 12 If project specific insurance endorsements are required, please add \$150.
- 13 SPT is a non-union contractor.
- 14 SPT requires 20 days notice to proceed. SPT will not be liable for LDs or other costs without adequate notice.
- 15 SPT is not responsible for thin asphalt or unstable base that will not support our equipment.
- 16 Delays or set up times exceeding 1 hour daily will be charged at \$500.00 per hour.
- 17 General Contractor must provide continuous pavement marking stripe with start/stop points marked unless drip line included below.
- 18 Please refer to SPT Job Number on top of page to ensure prompt processing of contracts and other project related documents.

Work Included

Milled Rumble Strips
Debris swept off of shoulder

Work Excluded

Installation of rumble strip types or patterns not specifically listed above i.e. intersection/transverse/full lane, sinusoidal, etc
Installation of rumble strips in areas not suitable for construction including but not limited to areas with edges/lips greater than 0.5", mountable curbs, and on extremely tight radiuses, such as curves or roundabouts.
Traffic Control
Fog Seal, flush seal or liquid asphalt coating if required

If SPT cannot construct this project as quoted (i.e. within the number of mobilizations included, and/or according to the work hours and construction shifts described above) please notify us so we may re-quote this project.

JOHN HOLBERT
CHIEF ESTIMATOR

Additional information regarding services can be found on our website
OFFICE: 717-697-1450 WWW.RUMBLESTRIPS.COM

Derek,

It takes about ½ day for each set of rumble strips (travel, layout, mark, cut, clean up and traffic).

We estimated the cost in 2 manners:

- Installation only (traffic control by Green Lake County) \$4,008.85
- Install and Traffic Control by Columbia \$8,313.47

Let us know what you decide. Thanks.

Sincerely,

Chris Hardy

Chris Hardy, P.E.

Highway Commissioner

Our Goal: Good, Safe Roads!

Columbia County

Highway & Transportation Department

P.O. Box 875

338 Old Highway 16 Road

Wyocena, WI 53969

(608) 429-2136

Green Lake County
8 Year - (2022-2029)
Highway Improvement Plan

Approved by Highway Committee _____

2022								
	Project Limits - Work Type	Location	PASER Rating	PASER Year	Traffic Count	Traffic Year	ESTIMATE	
CTH F	4.2 Miles S Hunter - County Line (cold in place)	Town of Seneca	2	2021	5314	2019		
CTH E	1.57 Miles CTH F-Dolata Bridge (cold in place)	Town of Seneca	2	2021	1588	2019	\$1,944,132.00	
TOTAL	5.77 Miles						\$1,944,132.00	

2023								
	Project Limits	Location	PASER Rating	PASER Year	Traffic Count	Traffic Year	ESTIMATE	
CTH J	7.68 Miles City of Princeton - STH 49 (pulverize, pave)	Town of St. Marie	2	2021	687	2019	\$2,500,000.00	
TOTAL	7.68 Miles						\$2,500,000.00	

2024								
	Project Limits	Location	PASER Rating	PASER Year	Traffic Count	Traffic Year	ESTIMATE	
CTH J	1.8 Miles City of Princeton - STH 49 (pulverize, pave)	Town of St. Marie	2	2021	687	2019	\$570,854.00	
CTH D	5.17 Miles STH 23/73 - STH 73 (pulverize, pave)	Town of Princeton	3	2021	1474	2019	\$2,003,891.00	
Total	6.97 Miles						\$2,574,745.00	

2025								
	Project Limits	Location	PASER Rating	PASER Year	Traffic Count	Traffic Year	ESTIMATE	
CTH A	4 Miles CTH I - CTH AW (cold in place)	Town of Mackford	3	2021	1000	2019	\$1,419,895.00	
CTH T	2 Miles Princeton - Bend Road (pulverize, pave)	Town of Princeton	2	2021	633	2019	\$632,680.00	
CTH GG	1.82 Miles CTH M - CTH HH (reconstruct)	Town of Manchesster	2	2021	365	2019	\$815,000.00	
CTH H	2.64 Miles Puckaway - CTH B/KK (reconstruct)	Village of Marquette	2	2021	506	2019	\$737,369.00	
Total	10.46 Miles						\$2,709,870.00	

2026								
	Project Limits	Location	PASER Rating	PASER Year	Traffic Count	Traffic Year	ESTIMATE	
CTH N	2.34 Miles CTH K - CTH B (reconstruct)	Town of Green Lake	2	2021	292	2019	\$685,700.00	
CTH O	1.75 Miles CTH K - CTH B (pulverize, pave)	Town of Green Lake	2	2021	158	2019	\$588,756.00	
CTH A	1 Miles CTH V - CTH AA (reconstruct)	Town of Berlin	2	2021	343	2019	\$407,611.00	
CTH H	2.34 Miles STH 44 - CTH B (reconstruct)	Town of Kingston	2	2021	399	2019	\$743,680.00	
TOTAL	7.43 Miles						\$2,425,747.00	

2027								
	Project Limits	Location	PASER Rating	PASER Year	Traffic Count	Traffic Year	ESTIMATE	
CTH JJ	1.2 Miles CTH Q - County Line (reconstruct)	Town of Green Lake	1	2021	98	2019	\$358,231.00	
CTH D	3 Miles CTH F - White River Bridge(Reconstruct, Marsh)	Town of St. Marie	2	2021	609	2019	\$2,129,060.00	
TOTAL	4.2 Miles						\$2,487,291.00	

2028								
	Project Limits	Location	PASER Rating	PASER Year	Traffic Count	Traffic Year	ESTIMATE	
CTH D	3.4 Miles CTH F - White River Bridge(Reconstruct, Marsh)	Town of St. Marie	2	2021	609	2019	\$2,412,935.00	
TOTAL	3.4 Miles						\$2,412,935.00	

2029								
	Project Limits	Location	PASER Rating	PASER Year	Traffic Count	Traffic Year	ESTIMATE	
CTH S	1.14 Miles CTH A - C. Markesan	Town of Mackford	2	2021	1300	2021	\$385,211.00	
CTH BB	1.1 Miles STH 73 - CTH B	Town of Marquette	2	2021	90		\$296,356.00	
CTH TT	1.5 Miles STH 23 - CTH T (reconstruct)	Town of Princeton	1	2021	71	2019	\$385,942.00	
TOTAL	3.74 Miles						\$1,067,509.00	

GTA / RECONSTRUCTION TOTALS

YEAR	Overlay \$	RECON \$	Total		GTA	Additional Short Term Borrowing
			Overlay/Recon	BUDGETED		
2012	776,314.00	778,029.00	1,554,343.00	1,092,479.00	750,530.00	
2013	113,174.00	1,111,791.00	1,224,965.00	1,116,356.00	786,937.00	
2014	636,957.00	391,743.00	1,028,700.00	1,114,051.00	762,346.00	
2015	560,370.00	798,344.00	1,358,714.00	1,433,652.00	777,087.00	
2016	0.00	1,066,421.00	1,066,421.00	1,468,812.00	743,181.00	
2017	498,781.00	1,062,665.00	1,561,446.00	1,459,353.00	719,950.00	
2018	264,067.00	905,522.00	1,169,589.00	1,390,488.00	805,197.00	
2019	0.00	1,824,027.00	1,824,027.00	1,200,624.00	802,511.00	
2020	0.00	1,842,588.00	1,842,588.00	1,982,940.00	885,594.00	500,000.00
2021	0.00	2,609,990.00	2,609,990.00	2,052,535.00	879,619.00	600,000.00
2022	0.00	*2,937,830.00	2,937,830.00	2,152,535.00	939,643.00	*as of 10/25 700,000.00
2023	0.00		0.00	2,400,000.00*	989,186.00	*Budgeted 800,000.00
			<u>18,178,613.00</u>			



GREEN LAKE COUNTY HIGHWAY COMMISSION

Derek Mashuda
Highway Commissioner

Office: 920-294-4060

Fax: 920-294-4066

Email: dmashuda@greenlakecountywi.gov

Commissioner's Report

November 9, 2022

Previous month review

- Mowing
- State RMA Mastic and Crack Seal
- V. Marquette Drainage Project
- CTH EF Miscellaneous
- State Shoulder work
- Started Truck Mounting
- New Scale Installation

Upcoming activates

- V. Marquette Crack Seal
- State Shoulder work
- Crack Sealing
- CTH EF Miscellaneous
- Truck Mounting
- Snow Fence Install
- Equipment Cleaning