



# ***GREEN LAKE COUNTY***

*571 County Road A, Green Lake, WI 54941*

---

**Original Post Date: 12/3/21**

**Amended\* Post Date:**

**The following documents are included in the packet for the Property and Insurance on December 6, 2021:**

- 1) Amended Agenda
- 2) Minutes from 11/2/2021
- 3) Resolution to Change Insurance Carriers
- 4) Information on Purchase of Equipment- Freezer, HHS
- 5) Maintenance Report



# GREEN LAKE COUNTY OFFICE OF THE COUNTY CLERK

Elizabeth Otto  
County Clerk

Office: 920-294-4005  
FAX: 920-294-4009

## Property & Insurance Committee Meeting Notice

**Date: December 7, 2021 Time: 4:30 PM**  
**Location: Government Center, County Board Room, 571 County Road A, Green Lake WI**

### Amended\* AGENDA

#### Committee Members

David Abendroth, Chair  
Charles Buss  
Patti Garro  
Richard Trochinski  
Keith Hess

Elizabeth Otto, Secretary

1. Call to Order
2. Certification of Open Meeting Law
3. Pledge of Allegiance
4. Approval of Minutes: 11/2/2021
5. Public Comment (3 Minute Limit)
6. Appearances
  - Buck Krueger, Cottingham and Butler – Update on 2022 Insurance other than Health Insurance
7. \*Resolutions
  - \*Resolution to Change Insurance Carrier
8. Purchase of Equipment – Freezer, HHS
9. Maintenance Report
  - Buildings and Grounds Report
  - Monthly Activities
10. Committee Discussion
  - Future Meeting Dates: Regular Meeting 1/4/2022 at 4:30 PM
  - Future Agenda items for action & discussion
11. Adjourn

Virtual attendance at meetings is optional. If technical difficulties arise, there may be instances when remote access may be compromised. If there is a quorum attending in person, the meeting will proceed as scheduled.

Due to the COVID-19 pandemic, this meeting will be conducted and available through in person attendance (6 ft. social distancing and face masks are required) or audio/visual communication. Remote access can be obtained through the following link:

Topic: Property and Insurance Meeting  
Time: Dec 7, 2021 04:30 PM Central Time (US and Canada)

Join Zoom Meeting

<https://us06web.zoom.us/j/89938574064?pwd=b1VOZjJyc3N3bG9kSzc0eWRLRU1Ndz09>

Meeting ID: 899 3857 4064  
Passcode: 080270

Dial by your location

+1 301 715 8592 US (Washington DC)  
+1 312 626 6799 US (Chicago)

Kindly arrange to be present, if unable to do so, please notify our office. Sincerely, Elizabeth Otto, County Clerk

**Please note: Meeting area is accessible to the physically disabled. Anyone planning to attend who needs visual or audio assistance, should contact the County Clerk's Office, 294-4005, not later than 3 days before date of the meeting.**

**PROPERTY AND INSURANCE COMMITTEE**  
**November 2, 2021**

The meeting of the Property and Insurance Committee was called to order by Chair Abendroth on Tuesday, November 2, 2021 at 4:39 PM in the Green Lake County Board Room, Green Lake County Government Center, 571 County Road A, Green Lake, WI. The meeting was held both in person and via Zoom. Requirements of the open meeting law were certified as being met. The pledge of allegiance was recited.

Present:        Dave Abendroth  
                  Chuck Buss  
                  Patti Garro  
                  Richard Trochinski  
                  Keith Hess

Other County employees present: Cathy Schmit, County Administrator; Scott Weir, Maintenance Supervisor; Liz Otto, County Clerk; Sheriff Mark Podoll; Dawn Klockow, Corporation Counsel (Zoom); various other county employees

**MINUTES**

*Motion/second (Garro/Buss)* to approve the minutes of October 5, 2021 with no corrections or updates. Motion carried with no negative vote.

**PUBLIC COMMENT**

Tracy Soda, Green Lake County retiree, spoke urging the committee to approve Group Health Trust (GHT) as the county health insurance plan for 2022-2023.

Sheriff Mark Podoll spoke urging the committee to approve GHT as the county health insurance plan for 2022-2023. He also spoke in favor of forming a separate employee committee to review health insurance options in the future.

**APPEARANCES**

• **Buck Krueger, Cottingham and Butler – Update on 2022 insurance other than health insurance**

Buck Krueger and Jacob Heins of Cottingham and Butler gave a presentation on the differences between our current liability/property/WC provider Wisconsin County Mutual and the broker/client relationship they can offer. There are a number of carriers interested in providing quotes for coverage and this will be presented at the December meeting. Discussion and questions followed regarding other services required such as Lexipol, safety training, and pre-claim services.

• **Todd Morris – Deer Donations Partners Program**

Todd Morris spoke on behalf of the Deer Donations Partners Program to request the use of either the highway grounds or the maintenance/food pantry site for deer donation drop-offs. They are in need of a local drop spot. There would be no cost to the county and deer would be picked up and taken to Fox Lake for processing.

## **RESOLUTIONS**

- **Resolution Relating to Green Lake County becoming a Deer Donation Site Sponsor**

*Motion/second (Garro/Hess)* to approve the resolution and forward to County Board for final approval. Motion carried with no negative vote.

- **Modify Health Insurance Plan Design and Update Personnel Policies and Procedures Manual**

An employee response spreadsheet was provided to committee members. Supervisor Abendroth requested a survey to find out if employees are willing to pay a higher percentage toward their premium than the current 8% or 12%.

*Motion/second (Buss/Trochinski)* to approve the resolution recommending Option 2 with GHT as the health insurance provider and forward to Personnel and County Board for final approval. Roll call vote – Ayes – Buss, Trochinski; Nays – Garro, Hess, Abendroth. Discussion held. *Motion Abendroth* to approve the resolution recommending Option 1 with State Plan PO17 as the health insurance plan and forward to County Board and Personnel for final approval. Motion dies – no second. *Motion/second (Buss/Garro)* to reconsider the vote on the health insurance option. Motion carried with no negative vote. New vote on original motion to approve the resolution recommending Option 2 with GHT as the health insurance provider and forward to Personnel and County Board for final approval. Roll call vote – Ayes – Buss, Trochinski, Garro; Nays – Hess, Abendroth. Motion carried.

## **PURCHASE OF EQUIPMENT – HIGHWAY BACKHOE LOADER**

Motion/second (Buss/Trochinski) to approve the bid from Caterpillar in the amount of \$144,500 for a backhoe loader with an additional \$5,750 for the extended warranty. Motion carried with no negative vote.

## **MAINTENANCE REPORT**

- Buildings and Grounds Report – no discussion on Scott Weir’s submitted report
- Monthly activities

## **COMMITTEE DISCUSSION**

**Future Meeting Date:** December 7, 2021 at 4:30 PM.

**Future Agenda items for action & discussion:**

## **ADJOURNMENT**

Chair Abendroth adjourned the meeting at 5:57 PM.

Submitted by,

Liz Otto  
County Clerk

**RESOLUTION NUMBER -2021**

**Resolution to Change Insurance Carrier**

The County Board of Supervisors of Green Lake County, Green Lake, Wisconsin, duly assembled at its regular meeting on this 21st day of December 2021, does resolve as follows:

- 1 **WHEREAS**, Wisconsin Statute §59.52(11) provides that the Board may provide public
- 2 liability, property damage to motor vehicles, malfeasance of professional
- 3 employees, maintenance and operation of county highways, parks, parkways and any
- 4 other county activities which may involve potential damage to the general public; and,
- 5 **WHEREAS**, Wisconsin Statute §59.52(11) provides that the Board may also provide for
- 6 fire and casualty insurance for all county property; and,
- 7 **WHEREAS**, Cottingham and Butler has gathered several bids from commercial
- 8 insurance providers who are willing to cover the County’s insurance needs; and,
- 9 Fiscal note is not applicable.
- 10 Majority vote is needed to pass.

Roll Call on Resolution No. -2021

Submitted by Property & Insurance Committee

Ayes , Nays , Absent , Abstain

\_\_\_\_\_  
David Abendroth, Chair

Passed and Adopted/Rejected this 21st day of December 2021.

\_\_\_\_\_  
Patti Garro

\_\_\_\_\_  
County Board Chairman

\_\_\_\_\_  
Charles Buss

\_\_\_\_\_  
ATTEST: County Clerk  
Approve as to Form:

\_\_\_\_\_  
Richard Trochinski

\_\_\_\_\_  
Corporation Counsel

\_\_\_\_\_  
Keith Hess

11 **WHEREAS**, Committee, along with the County Clerk have received and reviewed the  
12 insurance proposals from the several commercial insurance providers who provided  
13 quotes and has determined that significant savings may be realized by changing the  
14 County's insurance provider.

15 **NOW THEREFORE BE IT RESOLVED** that the Board of Supervisors of Green Lake  
16 County Wisconsin hereby accepts the insurance proposal of  
17 \_\_\_\_\_ as attached hereto.

18 **BE IT FURTHER RESOLVED** the County Clerk shall undertake whatever actions are  
19 necessary to implement the insurance change to  
20 \_\_\_\_\_.

21 **FISCAL NOTE:**

CALL US TOLL-FREE: 1-800-458-1716



Search By Keyword or Item #

SEARCH

[Commercial Equipment \(/c-5-commercial-equipment.aspx\)](#) > [Refrigeration \(/c-298-refrigeration.aspx\)](#) > [Freezers \(/c-419-freezers.aspx\)](#) > Turbo Air - Super Deluxe Freezer (35 CuFt)

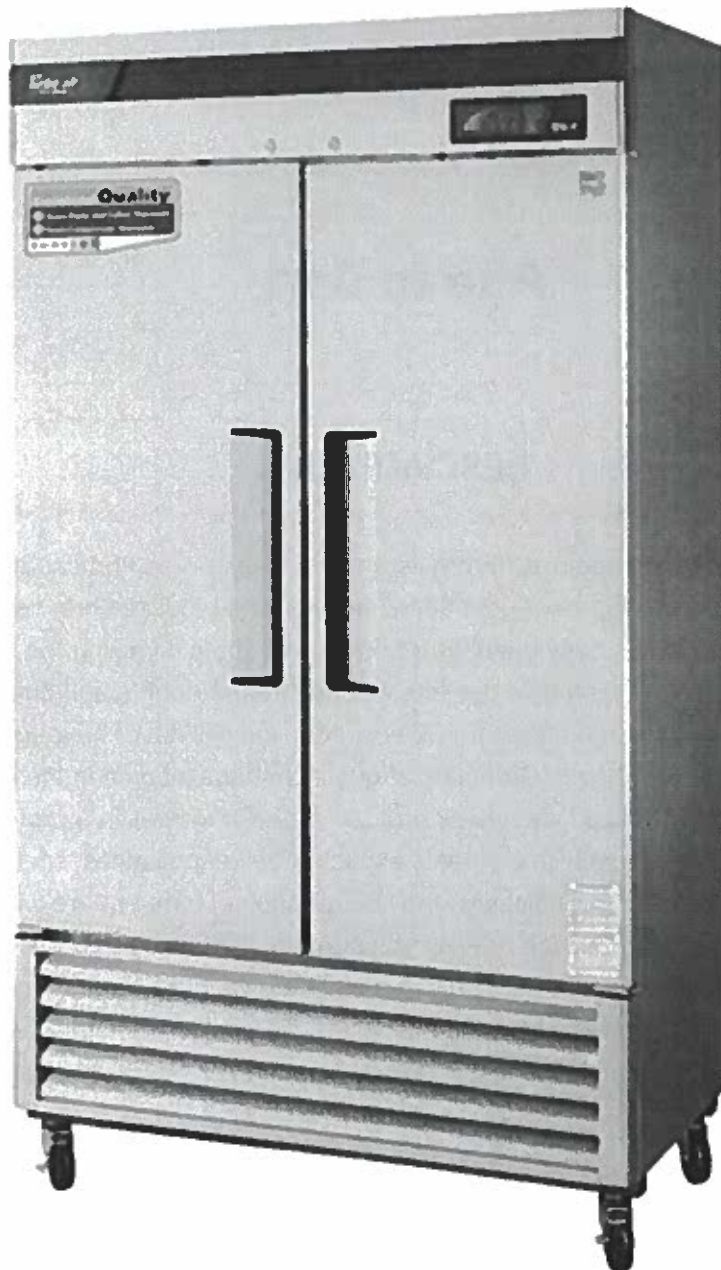

[View Larger Image](#)

[Share This:](#)

## Turbo Air - Super Deluxe Freezer (35 CuFt) (TSF-35SD)

MODEL: TSF-35SD

SKU: P13206

**Price: \$5,265.00**[Get Quote >](#) Usually Ships in 5-7 Days**Note: Inside delivery and lift-gate options are available for an additional fee. Call for more information.**Quantity **Add to Cart**

### DESCRIPTION

A Super Deluxe Freezer, is just that - "deluxe." From its materials, to its size and capacity, and all its features, it's the epitome of deluxe. Two swing out doors include long recessed handles making them both easy open; however, even though it is easy open, you won't worry about it lacking the ability to shut securely. Thanks to a combination of magnetic gaskets that secure the door, a self-closing design and an alarm that sounds after the door has been open for 30 seconds, you will never have to worry about the safety of your food in this Turbo Air freezer. Commercial-quality materials come in the form of stainless steel front, sides, and interior and a galvanized steel back and top, these work well in a professional kitchen environment. Turbo Air knows high quality and what is expected of its appliances, so it builds in what chefs need and what they want. An exterior LED displays the interior cabinet temperature without having to open the door. Within the cabinets you'll find a high density polyurethane insulation that is CFC free, along with clean and sturdy stainless steel shelves that are built to handle the weight asked of it. While most commercial refrigeration systems contain PVC coated shelves, Turbo Air uses stainless steel to prevent chipping or rusting that leads to sanitation issues. Powered by a 3/4 HP motor, this Energy Star rated freezer uses its power efficiently.

NSF Listed/cETLus

### Features

- Model: TSF-35SD
- Color: Silver



- Material: Stainless Steel/Galvanized Steel
- Dimensions: 39 1/2"L x 30 3/8"D x 78 1/4"H
- Capacity: 35 cubic feet

## PRODUCT REVIEWS

 (0.00)

# of Ratings: 0

(Only registered customers can rate)

[ABOUT \(/t-about.aspx\)](/t-about.aspx)

[CONTACT \(/t-contact.aspx\)](/t-contact.aspx)

[POLICIES \(/t-policies.aspx\)](/t-policies.aspx)

[CUSTOMER SERVICE \(/t-service.aspx\)](/t-service.aspx)

 (<https://www.facebook.com/PublicKitchenSupply>)

 (<https://pinterest.com/publickitchens/>)

 (<https://plus.google.com/+PublicKitchenSupply>)

 (<https://twitter.com/publickitchens>)

 (<https://www.youtube.com/user/PublicKitchenSupply>)

VISA



© 2019 PublicKitchenSupply.com – All Rights Reserved.

**MORIARTY REFRIGERATION SALES AND SERVICE LLC  
318 N WASHINGTON ST  
BERLIN, WI 54923  
920-361-0747**

November 11, 2021

Green Lake County Food Pantry  
500 Lake Steel St  
Green Lake, WI 54941

**Freezer Quote**

True 2 door freezer model T-35F-HC, see attached sped sheet for complete details. Price includes delivery, installation and disposal of an old unit if needed.

Total \$ 5573.00

Thank you,

Angie Bulow  
Office Manager  
Moriarty Refrigeration Sales and Service LLC

 <b>TRUE FOOD SERVICE EQUIPMENT, INC.</b> 2001 East Terra Lane • O'Fallon, Missouri 63366-4434 • (636)240-2400 Fax (636)272-2408 • Toll Free (800)325-6152 • Intl Fax# (001)636-272-7546 Parts Dept. (800)424-TRUE • Parts Dept. Fax# (636)272-9471 • www.truevmfg.com	Project Name: _____ Location: _____ Item #: _____ Qty: _____ Model #: _____	AIA # _____ SIS # _____
	<b>Model: T-35F-HC</b>	

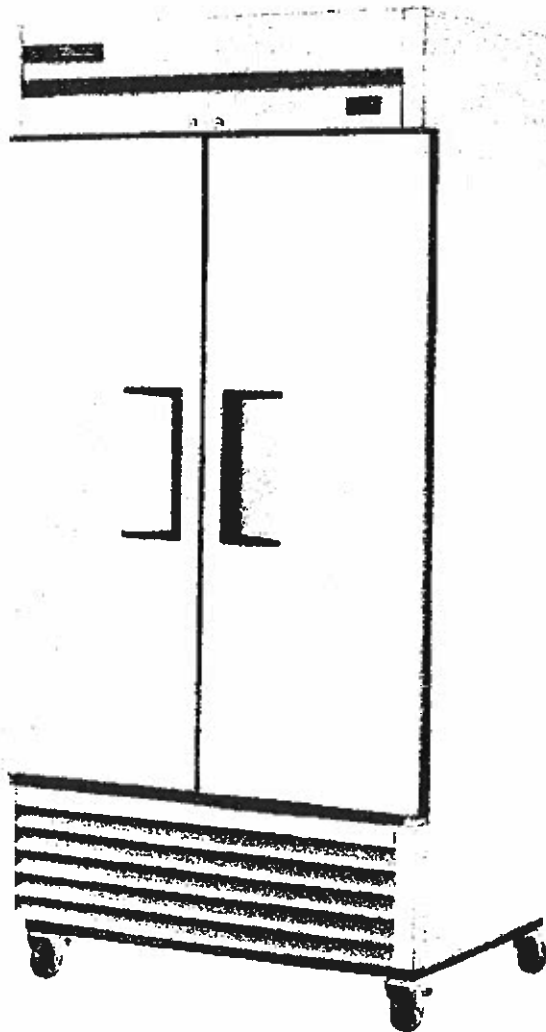

**T-35F-HC**



- ▶ True's solid door reach-ins are designed with enduring quality that protects your long term investment.
  - ▶ Designed using the highest quality materials and components to provide the user with colder product temperatures, lower utility costs, exceptional food safety and the best value in today's food service marketplace.
  - ▶ Factory engineered, self-contained, capillary tube system using environmentally friendly R290 hydro carbon refrigerant that has zero (0) ozone depletion potential (ODP), & three (3) global warming potential (GWP).
  - ▶ High capacity, factory balanced refrigeration system that maintains -10°F (-23.3°C) temperatures. Ideal for both frozen foods and ice cream.
  - ▶ Stainless steel solid doors and front. The finest stainless available with higher tensile strength for fewer dents and scratches.
  - ▶ Adjustable, heavy duty PVC coated shelves.
  - ▶ Positive seal self-closing doors. Lifetime guaranteed door hinges and torsion type closure system.
  - ▶ Automatic defrost system time-initiated, temperature-terminated. Saves energy consumption and provides shortest possible defrost cycle.
- Bottom mounted units feature:**
- ▶ "No stoop" lower shelf.
  - ▶ Storage on top of cabinet.
  - ▶ Compressor performs in coolest, most grease free area of kitchen.
  - ▶ Easily accessible condenser coil for cleaning.

**ROUGH-IN DATA**

Specifications subject to change without notice.  
 Chart dimensions rounded up to the nearest 1/4" (millimeters rounded up to next whole number).

Model	Doors	Shelves	Cabinet Dimensions (inches) (mm)			HP	Voltage	Amps	NEMA Config.	Cord Length (total ft.) (total m)	Crated Weight (lbs.) (kg)
			W	D	H*						
T-35F-HC	2	6	39½ 1004	29½ 750	78¾ 1991	1 N/A	115/60/1	9.6 N/A	5-15P	9 2.74	350 159

\* Height does not include 5" (127 mm) for castors or 6" (153 mm) for optional legs.

   	<b>APPROVALS:</b> _____	<b>AVAILABLE AT:</b> _____
5/17 Printed in U.S.A.		

Model:  
**T-35F-HC**

**T-Series:**  
Reach-in Solid Swing Door -10°F Freezer with  
Hydrocarbon Refrigerant



**STANDARD FEATURES**

**DESIGN**

- True's commitment to using the highest quality materials and oversized refrigeration systems provides the user with colder product temperatures, lower utility costs, exceptional food safety and the best value in today's food service marketplace.

**REFRIGERATION SYSTEM**

- Factory engineered, self-contained, capillary tube system using environmentally friendly R290 hydro carbon refrigerant that has zero (0) ozone depletion potential (ODP), & three (3) global warming potential (GWP).
- High capacity, factory balanced refrigeration system that maintains -10°F (-23.3°C) temperatures. Ideal for both frozen foods and ice cream.
- State of the art, electronically commutated evaporator and condenser fan motors. ECM motors operate at higher peak efficiencies and move a more consistent volume of air which produces less heat, reduces energy consumption and provides greater motor reliability.
- Bottom mounted condensing unit positioned for easy cleaning. Compressor runs in coolest and most grease free area of the kitchen. Allows for storage area on top of unit.
- Automatic defrost system time-initiated, temperature-terminated. Saves energy consumption and provides shortest possible defrost cycle.

**CABINET CONSTRUCTION**

- Exterior - Stainless steel front. Anodized quality aluminum ends. Corrosion resistant GalFan coated steel back.
- Interior - attractive, NSF approved, clear coated aluminum liner. Stainless steel floor with coved corners.
- Insulation - entire cabinet structure and solid doors are foamed-in-place using a high density, polyurethane insulation that has zero ozone depletion potential (ODP) and zero global warming potential (GWP).
- Welded, heavy duty steel frame rail, black powder coated for corrosion protection.
- Frame rail fitted with 4" (102 mm) diameter stem castors - locks provided on front set.

**DOORS**

- Stainless steel exterior with clear aluminum liners to match cabinet interior. Doors extend full width of cabinet shell. Door locks standard.
- Lifetime guaranteed recessed door handles. Each door fitted with 12" (305 mm) long recessed handle that is foamed-in-place with a sheet metal interlock to ensure permanent attachment.
- Positive seal self-closing doors. Lifetime guaranteed door hinges and torsion type closure system.
- Magnetic door gaskets of one piece construction, removable without tools for ease of cleaning.

**SHELVING**

- Six (6) adjustable, heavy duty PVC coated wire shelves 17 1/2" L x 22 3/8" D (445 mm x 569 mm). Four (4) chrome plated shelf clips included per shelf.
- Shelf support pilasters made of same material as cabinet interior; shelves are adjustable on 1/2" (13 mm) increments.

**LIGHTING**

- Interior lighting - safety shielded. Lights activated by rocker switch mounted above doors.

**MODEL FEATURES**

- Exterior temperature display.
- Evaporator is epoxy coated to eliminate the potential of corrosion.
- Rear airflow guards prevent product from blocking optimal airflow.
- NSF/ANSI Standard 7 compliant for open food product.

**ELECTRICAL**

- Unit completely pre-wired at factory and ready for final connection to a 115/60/1 phase, 15 amp dedicated outlet. Cord and plug set included.



115/60/1  
NEMA-5-15R

**OPTIONAL FEATURES/ACCESSORIES**

- Upcharge and lead times may apply.
- 6" (153 mm) standard legs.
  - 6" (153 mm) seismic/flanged legs.
  - Additional shelves.

**PLAN VIEW**

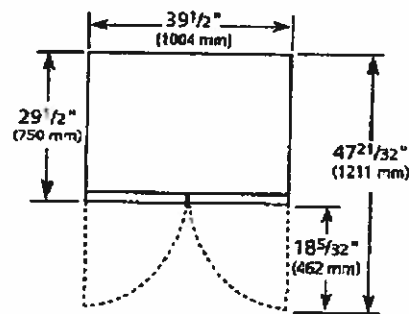
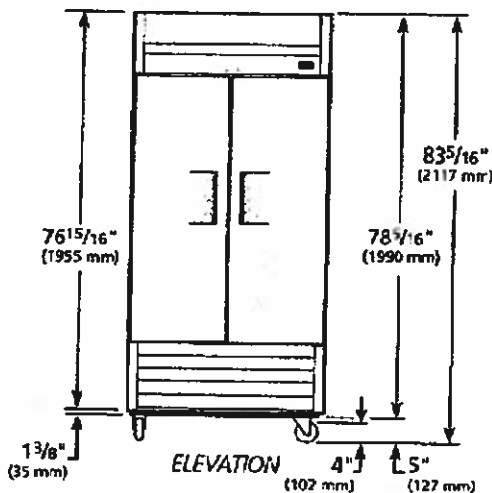

PLAN VIEW

**WARRANTY\***  
Three year warranty on all parts and labor and an additional 2 year warranty on compressor. (U.S.A. only)

METRIC DIMENSIONS ROUNDED UP TO THE NEAREST WHOLE MILLIMETER

SPECIFICATIONS SUBJECT TO CHANGE WITHOUT NOTICE

	Model	Elevation	Right	Plan	3D	Back
	T-35F-HC	TFEY18E	TFEY04S	TFEY04P	TFEY183	

\*RESIDENTIAL APPLICATIONS: True assumes no liability for parts or labor coverage for component failure, factory defect or any other damages for units installed in non-commercial foodservice or residential applications.

**TRUE FOOD SERVICE EQUIPMENT**

December 07, 2021  
Property & Insurance Committee  
Monthly Report  
Green Lake County Maintenance Department

#### 571 County Road A

Replaced relay in HP 223 services unit J - Corrections  
Installed new timer in locking mech. Unit A detention door – Corrections  
Replaced 1 lamp in light fixture rec. 3 – Corrections  
Repaired flush handle master control staff restroom - Corrections  
Replaced 1 lamp in light fixture rec. 4 - Correction  
Replaced lamp in fixture unit d cell #3 – Corrections  
Replaced lamp in fixture stove top hood/kitchen – Corrections  
Replaced lamp in fixture 2' unit M by TV – Corrections  
Painted over scratched in graffiti metal window frame rec. #4 – Corrections  
Replaced lamp in light fixture male locker room above dryers - Correction  
Unplugged Master Control staff sink – Corrections  
Report of pre wash spray nozzle not spraying well-kitchen/Cleaned pre was spray nozzle/food debris – Corrections  
Report of booking staff restroom sink draining slowly/cleaned/food debris - Corrections  
Report of Dorm A continue to cycle sometimes more than 10 times/check door cycle with master control door cycled only when activated/ tested 16 times for cycle no fails/checked micro switches on cam all working/lubed and reassembled/tested again 2 cycles no fails. - Corrections  
Replaced guard button unit B top tier - Corrections  
Replacement optional garbage disposal unit for jail kitchen pre auto dishwasher area ordered per request (\$2,222.87) – Corrections  
Re-lit pilot lights jail kitchen stove top per request - Corrections  
Replaced lamp in light fixture south entrance jail – Corrections  
Replaced guard button lower area Unit E - Corrections  
Replaced lamp in light fixture unit M day room above first bunk - Corrections  
Replaced guard button intake interview room #1 – Corrections  
Replaced lamps in light fixture corrections vestibule – Corrections  
Replaced lamps in light fixture corrections lobby – Corrections  
Replaced lamp in light fixture above kitchen office door - Corrections  
Replaced supplied parts for 3 communications chairs – Communications  
Installed 2 tv wall mount brackets along with tv's room #1243 – SO  
Replaced worn HP spray nozzle along with swivel barbed 3/4" fitting – SO  
Installed sound bar for TV room #1246 – SO  
Filled and treated fuel for back-up generator 11/17/21 - SO  
Replaced expired power pak light circuit phase 2 west stairwell  
Lube axles purchasing delivery cart - CC  
Installed brackets along with shelf at highway dept. shop #1 office area per request – IT  
Replaced expired exhaust manifold gaskets- related fasteners, muffler on 2011 Ram - MPR

Scheduled Maintenance performed  
General Maintenance performed

500 Lake Steel Street

HVAC changed to winter mode- Maint./Food Pantry areas  
Removed expired upright freezer per request - Food Pantry/HHS  
Lubed wheels on food carts per request – Food Pantry  
Relocated upright freezer to west entrance/exit area per request – Food Pantry  
Scheduled Maintenance performed  
General Maintenance performed

Tower Sites

Princeton  
Markesan  
Kingston – Replaced expired block heater 11/22/21  
Berlin – Replacement parts installed 11/09/21 back up generator/generator back on-line  
Changed oil in back-up generator motor  
Green Lake  
Scheduled Maintenance performed  
General Maintenance performed

Submitted by:

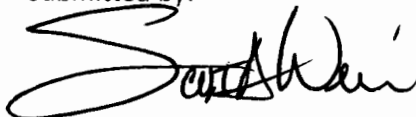
A handwritten signature in black ink, appearing to read "Scott A. Weir". The signature is stylized with a large, sweeping initial "S" and a cursive "A. Weir".

Scott A. Weir  
Maintenance Director  
Green Lake County